

POSITAPE®
WB10ZG
Analog Output

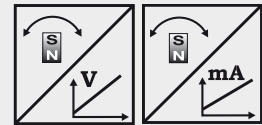

Position sensor with measuring tape

- Measurement range up to 2000 mm
- Protection class IP65
- Stainless steel measuring tape
- Analog output



Specifications	Outputs	U2	Voltage 0.5 ... 10 V
		U8	Voltage 0.5 ... 4.5 V
	I1	Current 4 ... 20 mA, 3 wire	
	Resolution		<0,05 mm
	Linearity		±0.10 % f. s. (standard); optional ±0.05 %
	Sensing device		Magnetic absolute encoder
	Material		Zinc diecast, aluminium, plastic and stainless steel; Tape: stainless steel, 10 mm wide, 0.08 mm thick
	Protection class		IP65 (with mating connector)
	Connection		Connector M12, 5 pin
	Shock		EN 60068-2-27:2010, 100 g/11 ms, 100 shocks
	Vibration		EN 60068-2-6:2008, 20 g 10 Hz-2 kHz, 10 cycles
	Temperature range		-20 ... +85 °C

Order code WB10ZG



Model name

Measurement range (in mm)

250 / 375 / 500 / 750 / 1000 / 1250 / 1500 / 2000

Output

- U2 = 0.5 ... 10 V signal conditioner
- U8 = 0.5 ... 4.5 V signal conditioner
- I1 = 4 ... 20 mA signal conditioner

Signal characteristics

- A = increasing (eg. 4 ... 20 mA)
- D = decreasing (eg. 20 ... 4 mA)

Linearity

- L10 = ±0.10 % (standard)
- L05 = ±0.05 % (optional, only for measurement ranges ≥1000 mm)

Connection

M12A5 = connector M12, 5 pin

Dust wiper

BAB1

Order code connector cable see page 12

Order example: WB10ZG - 1250 - U2 - A - L10 - M12A5 - BAB1



Position sensor with measuring tape

- Measurement range up to 2000 mm
- Protection class IP65
- Stainless steel measuring tape
- Analog output, programmable

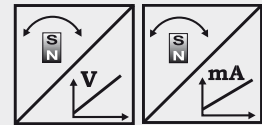

Specifications	Output	U2/PMU U8/PMU I1/PMU	Voltage 0.5 ... 10 V, programmable Voltage 0.5 ... 4.5 V, programmable Current 4 ... 20 mA, 3 wire, programmable
	Resolution		
Linearity			±0.10 % f. s. (standard); optional ±0.05 %
Sensing device			Magnetic absolute encoder
Material			Zinc diecast, aluminium, plastic and stainless steel; Tape: stainless steel, 10 mm wide, 0.08 mm thick
Protection class			IP65 (with mating connector only)
Connection			Connector M12, 5 pin
Shock			EN 60068-2-27:2010, 100 g/11 ms, 100 shocks
Vibration			EN 60068-2-6:2008, 20 g 10 Hz-2 kHz, 10 cycles
Temperature range			-20 ... +85 °C

Order code WB10ZG



Model name

Measurement range (in mm)

250 / 375 / 500 / 750 / 1000 / 1250 / 1500 / 2000

Output

- U2/PMU = 0.5 ... 10 V signal conditioner, programmable
- U8/PMU = 0.5 ... 4.5 V signal conditioner, programmable
- I1/PMU = 4 ... 20 mA signal conditioner, programmable

Signal characteristics

- A = increasing (eg. 4 ... 20 mA)
- D = decreasing (eg. 20 ... 4 mA)

Linearity

- L10 = ±0.10 % (standard)
- L05 = ±0.05 % (optional, only for measurement ranges ≥1000 mm)

Connection

M12A5 = Connector M12, 5 pin

Dust wiper

BAB1

Order code connector cable see page 13

Order example: WB10ZG - 2000 - U2/PMU - A - L10 - M12A5 - BAB1

POSITAPE®
WB10ZG
Digital Output SSI



Position sensor with measuring tape

- Measurement range up to 2000 mm
- Protection class IP65
- Stainless steel measuring tape
- Digital output SSI

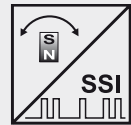

Specifications	Outputs	Synchronous serial interface (SSI)
	Resolution	up to 10 µm
	Linearity	±0.10 % f. s. (standard); optional ±0.05 %
	Sensing device	Magnetic absolute encoder
	Material	Zinc diecast, aluminium and plastic Tape: stainless steel, 10 mm wide, 0.08 mm thick
	Protection class	IP65 (with mating connector only)
	Connection	Connector M12, 8 pin
	Shock	EN 60068-2-27:2010, 100 g/11 ms, 100 shocks
	Vibration	EN 60068-2-6:2008, 20 g 10 Hz-2 kHz, 10 cycles
	Temperature range	-20 ... +85 °C

Order code WB10ZG

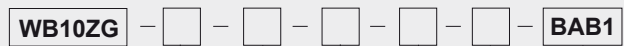

Model name

Measurement range (in mm)

1000 / 2000

Resolution (in µm)

10 / 50 / 100

Outputs

MSSI = SSI synchronous serial interface

Linearity

L10 = ±0.10% (standard)

L05 = ±0.05% (optional)

Connection

M12A8 = Connector M12, 8 pin

Dust wiper

BAB1

Order code connector cable see page 14

Order example: WB10ZG - 2000 - 100 - MSSI - L10 - M12A8 - BAB1

POSITAPE®
WB10ZG
Digital output CANopen



Position sensor with measuring tape

- Measurement range up to 2000 mm
- Protection class IP65
- Stainless steel measuring tape
- Digital output CANopen or CAN SAE J1939

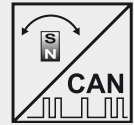

Specifications	Outputs	CANopen or CAN SAE J1939
	Resolution	setting via CAN Bus
	Linearity	±0.10 % f. s. (standard); optional ±0.05 %
	Sensing device	Magnetic absolute encoder
	Material	Zinc diecast, aluminium, plastic and stainless steel; Tape: stainless steel, 10 mm wide, 0.08 mm thick
	Protection class	IP65 (with mating connector only)
	Connection	Connector M12, 5 pin
	Shock	EN 60068-2-27:2010, 100 g/11 ms, 100 shocks
	Vibration	EN 60068-2-6:2008, 20 g 10 Hz-2 kHz, 10 cycles
	Temperature range	-20 ... +85 °C

Order code WB10ZG

WB10ZG - [] - [] - [] - [] - BAB1

- Model name**
- Measurement range (in mm)**
1000 / 2000
- Output**
MCANOP = CANopen
MCANJ1939 = CAN SAE J1939
- Linearity**
L10 = 0.10% (standard)
L05 = 0.05% (optional)
- Connection**
M12/CAN = Connector M12, 5 pin
- Dust wiper**
BAB1

Order code connector cable see page 15

Order example: WB10ZG - 2000 - MCANOP - L10 - M12/CAN - BAB1

Outline drawing WB10ZG
up to 1000 mm

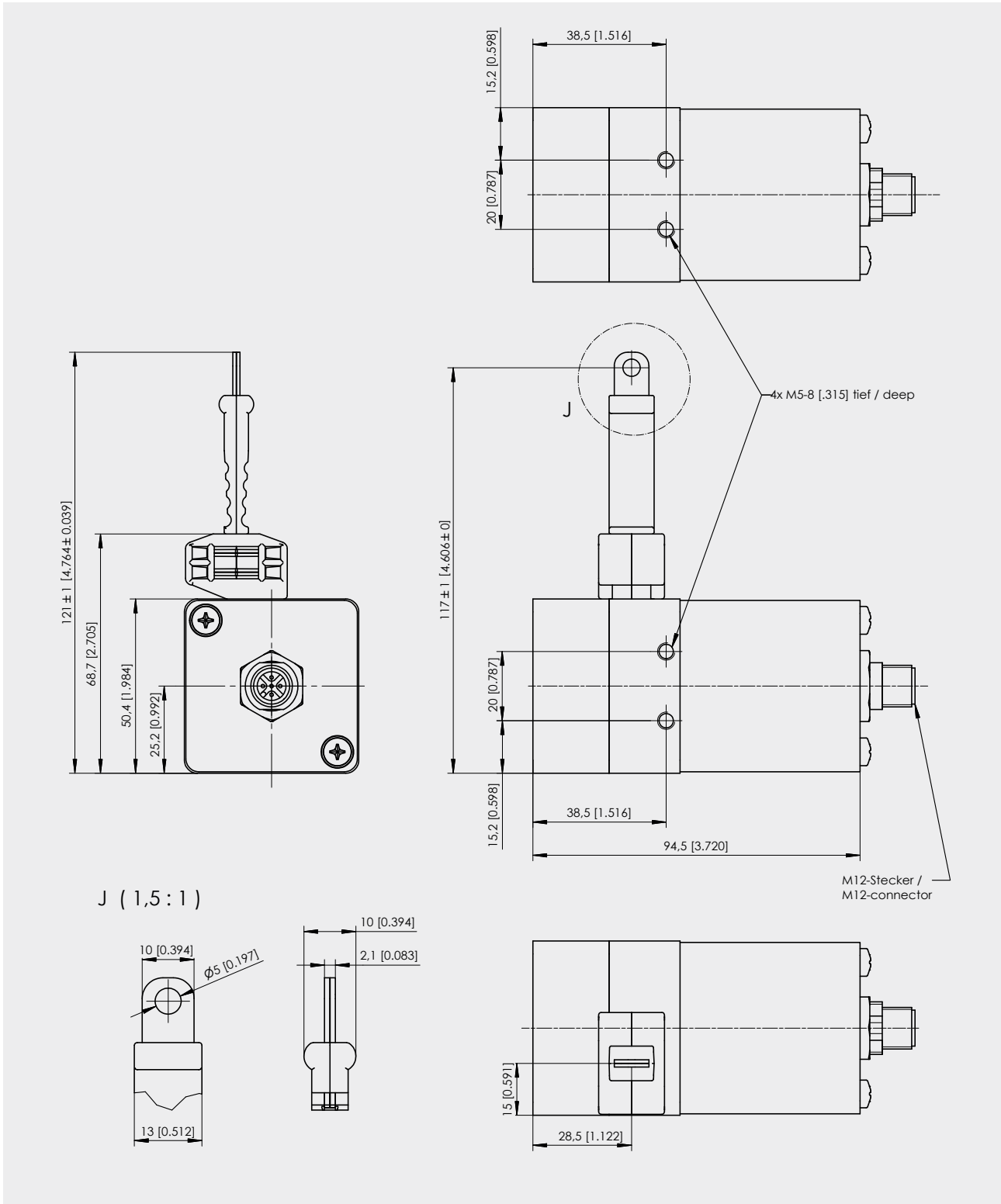

Dimensions in mm [inch]

Dimensions informative only.
For guaranteed dimensions consult factory.

POSITAPE®
WB10ZG
Dimensions



Outline drawing WB10ZG
 1250 / 1500 / 2000 mm

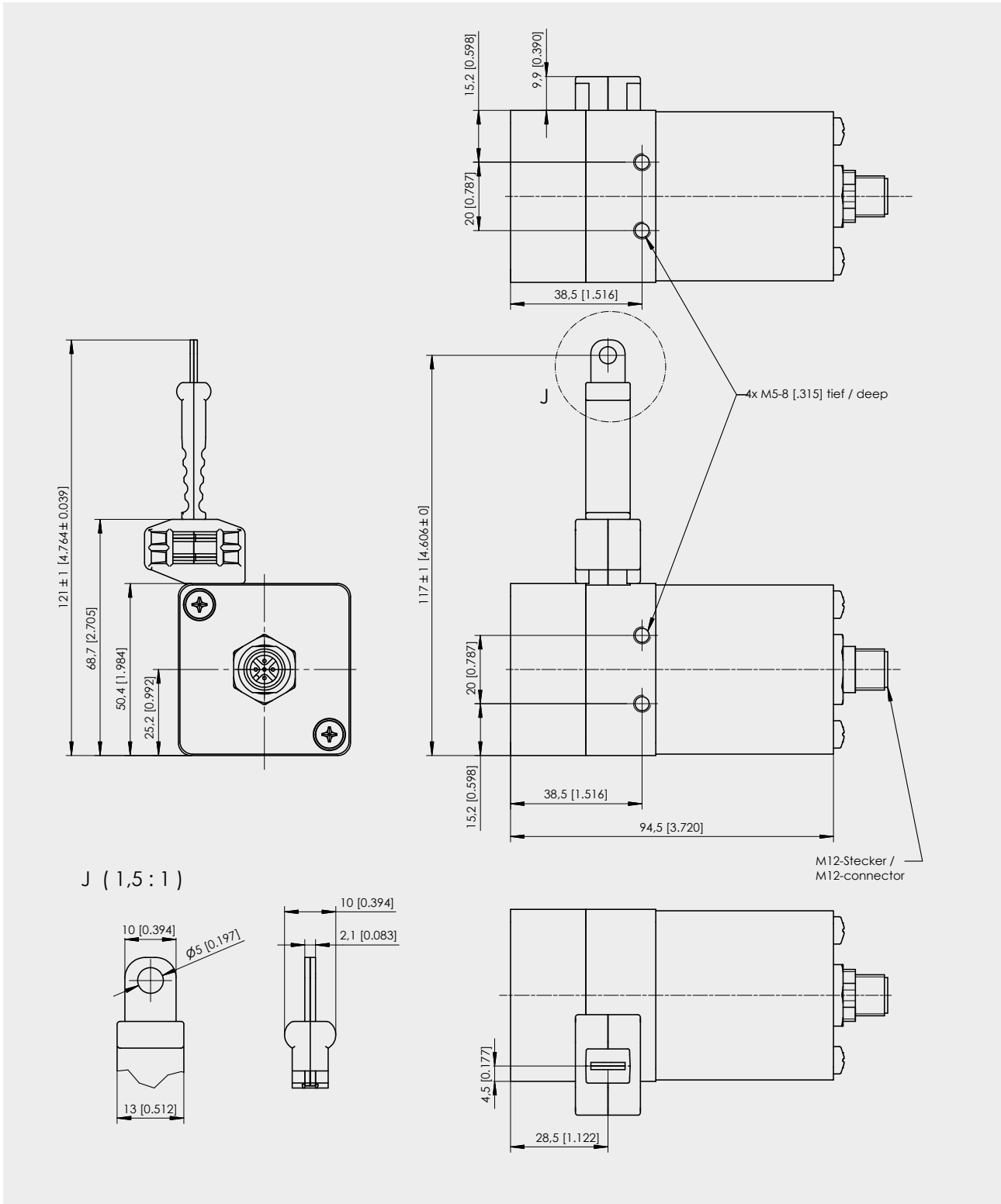

Dimensions in mm [inch]

Dimensions informative only.
 For guaranteed dimensions consult factory.

POSITAPE®

U2, U8 and I1

Analog Outputs

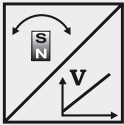

U2 Voltage output 0.5 ... 10 V 	Excitation voltage	10 ... 36 V DC
	Excitation current	typ. 20 mA at 24 V DC typ. 20 mA at 24 V DC max. 60 mA
	Output voltage	0,5 ... 10 V DC
	Output current	2 mA max.
	Measuring rate	1 kHz standard
	Stability (temperature)	$\pm 50 \times 10^{-6}/^{\circ}\text{C}$ f.s. (typical)
	Protection	Reverse polarity, short circuit
	Operating temperature	See specification of the respective sensor
	EMC	EN 61326-1:2013

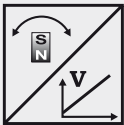
U8 Voltage output 0.5 ... 4.5 V 	Excitation voltage	10 ... 36 V DC
	Excitation current	typ. 17 mA at 24 V DC typ. 32mA at 12 V DC max. 60 mA
	Output voltage	0,5 ... 4,5 V DC
	Output current	2 mA max.
	Measuring rate	1 kHz standard
	Stability (temperature)	$\pm 50 \times 10^{-6}/^{\circ}\text{C}$ f.s. (typical)
	Protection	Reverse polarity, short circuit
	Operating temperature	See specification of the respective sensor
	EMC	EN 61326-1:2013

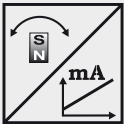
I1 Current output 4 ... 20 mA, 3 wire 	Excitation voltage	10 ... 36 V DC
	Excitation current	typ. 36 mA at 24 V DC typ. 70 mA at 12 V DC max. 100 mA
	Load R_L	500 Ω max.
	Output current	4 ... 20 mA
	Measuring rate	1 kHz standard
	Stability (temperature)	$\pm 50 \times 10^{-6}/^{\circ}\text{C}$ f.s. (typical)
	Protection	Reverse polarity, short circuit
	Operating temperature	See specification of the respective sensor
	EMC	EN 61326-1:2013

Output signals

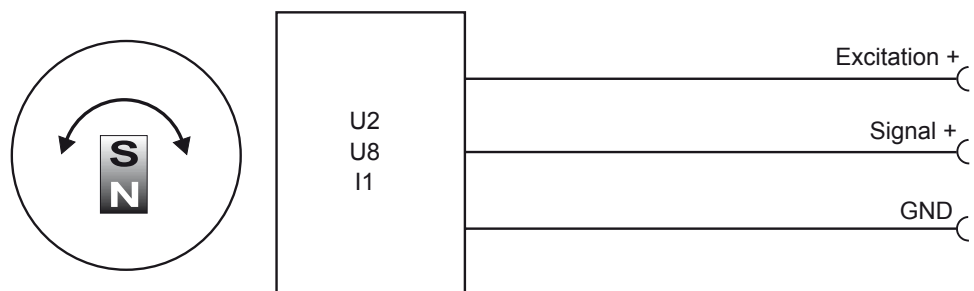

Signal wiring/ connection	Output signal	Connector pin	Cable wire color
	Excitation +	1	brown
	Signal	2	white
	GND	3	blue
	Do not connect!	4	black
	Do not connect!	5	(grey)

View to sensor
connector

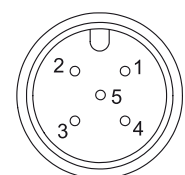

U2/PMU Voltage output 0.5 ... 10 V 	Excitation voltage	10 ... 36 V DC
	Excitation current	typ. 20 mA at 24 V DC, typ. 38 mA at 12 V DC, max. 60 mA
	Output voltage	0,5 ... 10 V DC
	Output current	2 mA max.
	Measuring rate	1 kHz standard
	Stability (temperature)	±50 x 10 ⁻⁶ /°C f.s. (typical)
	Protection	Reverse polarity, short circuit
	Operating temperature	See specification of the respective sensor
	EMC	EN 61326-1:2013
	U8/PMU Voltage output 0.5 ... 4,5 V 	Excitation voltage
Excitation current		typ. 17 mA at 24 V DC, typ. 32 mA at 12 V DC, max. 60 mA
Output voltage		0,5 ... 4,5 V DC
Output current		2 mA max.
Measuring rate		1 kHz standard
Stability (temperature)		±50 x 10 ⁻⁶ /°C f.s. (typical)
Protection		Reverse polarity, short circuit
Operating temperature		See specification of the respective sensor
EMC		EN 61326-1:2013
I1/PMU Current output 4 ... 20 mA, 3 wire 		Excitation voltage
	Excitation current	typ. 36 mA at 24 V DC, typ. 70 mA at 12 V DC, max. 100 mA
	Load R _L	500 Ω max.
	Output current	4 ... 20 mA
	Measuring rate	1 kHz standard
	Stability (temperature)	±50 x 10 ⁻⁶ /°C f.s. (typical)
	Protection	Reverse polarity, short circuit
	Operating temperature	See specification of the respective sensor
	EMC	EN 61326-1:2013

Output signals

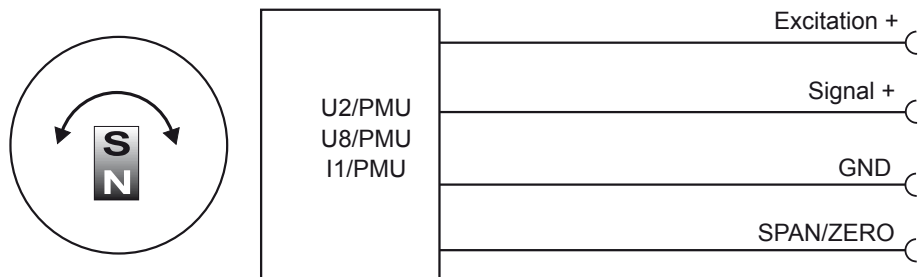

Signal wiring/ connection	Signal	Connector pin	Cable wire color
	Excitation +	1	brown
	Signal	2	white
	GND	3	blue
	Do not connect!	4	black
	SPAN/ZERO	5	grey

View to sensor connector

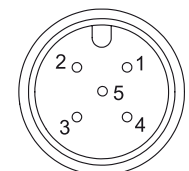

Option -PMU

Programming of the start and end value by the customer

Teach-In of start and end value for the options U2/PMU, I1/PMU, U8/PMU is provided by a binary signal SPAN/ZERO. At the start position connect signal SPAN/ZERO for a period of 2 ... 3 seconds to GND via push button. At the end position connect signal SPAN/ZERO for a period of 5 ... 6 seconds to GND via a push button. The teachd positions will be stored non-volatile.

To reset the sensor to factory default signal ZERO/END must be connected to ground while powering up the sensor for 2 ... 3 seconds.

MSSI Synchronous serial SSI 	Interface	EIA RS-422
	Excitation voltage	8 ... 36 V DC
	Excitation current	typ. 19 mA at 24 V DC, typ. 35 mA at 12 V DC, 80 mA max.
	Clock frequency	100 kHz ... 500 kHz
	Code	Gray-Code, continuous progression, 24 bit
	Delay between pulse trains	20 µs min.
	Stability (temperature)	$\pm 50 \times 10^{-6} / ^\circ\text{C}$ f.s. (typical)
	Operating temperature	See specification of the respective sensor
	Protection	Short circuit
	EMC	EN 61326-1:2013

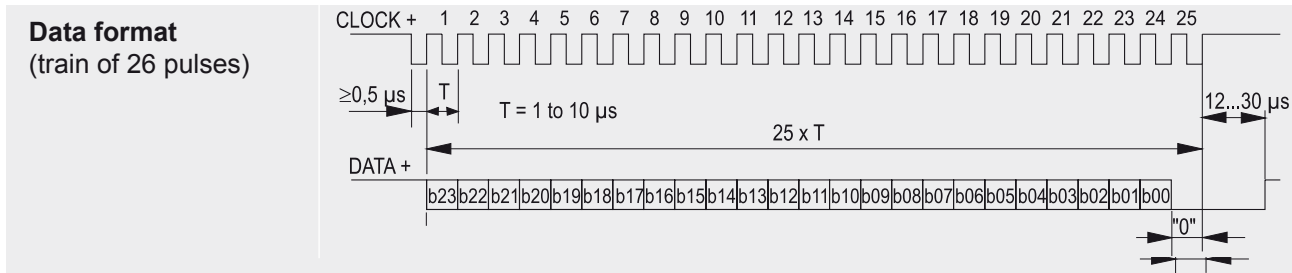

Recommended processing circuit

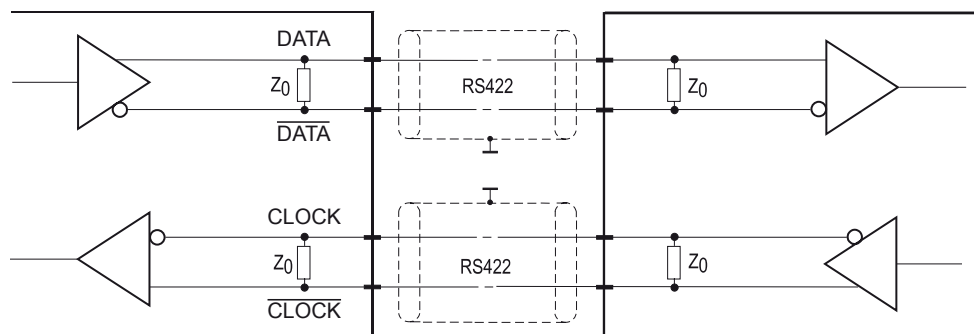



Transmission rate	Cable length	Baud rate
	50 m	100-400 kHz
	100 m	100-300 kHz

Note:
 Extension of the cable length will reduce the maximum transmission rate.

Signal wiring/ connection	Signal name	Connector pin
	Excitation +	1
	Excitation GND	2
	CLOCK	3
	CLOCK	4
	DATA	5
	DATA	6
	-	7
	-	8

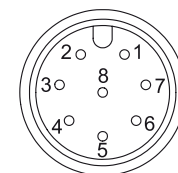
View to sensor connector



MCANOP CANopen 	Communication profile	CANopen CiA 301 V 4.02, Slave
	Encoder profile	Encoder CiA 406 V 3.2
	Error Control	Node Guarding, Heartbeat, Emergency Message
	Node ID	Adjustable via LSS; default: 127
	PDO	3 TxPDO, 0 RxPDO, no linking, static mapping
	PDO Modes	Event-/Time triggered, Remote-request, Sync cyclic/acyclic
	SDO	1 server, 0 client
	CAM	2 cams
	Certified	Yes
	Transmission rates	50 kbit to 1 Mbit, adjustable via LSS; default: 125 kbit
	Bus connection	M12 connector, 5 pins
	Integrated bus terminating resistor	120Ω adjustable by the customer
	Bus, galvanic isolated	No

Specifications	Excitation voltage	8 ... 36 V DC
	Excitation current	typ. 20 mA at 24 V typ. 40 mA at 12 V max. 80 mA
	Measuring rate	1 kHz (asynchronous)
	Stability (temperature)	$\pm 50 \times 10^{-6} / ^\circ\text{C}$ f.s.
	Repeatability	1 LSB
	Operating temperature	See specification of the respective sensor
	Protection	Reverse polarity, short circuit
	Dielectric strength	1 kV (V AC, 50 Hz, 1 min.)
	EMC	EN 61326-1:2013

Signal wiring/ connection	Signal name	Connector pin no.
	Shield	1
	Excitation +	2
	GND	3
	CAN-H	4
	CAN-L	5

View to sensor connector

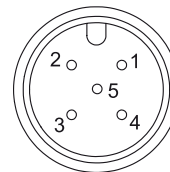

POSITAPE®
MMCANJ1939
Output CAN SAE J1939



MCANJ1939 CAN SAE J1939 	CAN specification	ISO 11898, Basic and Full CAN 2.0 B
	Transceiver	24V-compliant, not isolated
	Communication profile	SAE J1939
	Baud rate	250 kbit/s
	Internal termination resistor	120 Ω adjustable by the customer
	Address	Default 247d, configurable

NAME Fields	Arbitrary address capable	1	Yes
	Industry group	0	Global
	Vehicle system	7Fh (127d)	Non specific
	Vehicle system instance	0	
	Function	FFh (255d)	Non specific
	Function instance	0	
	ECU instance	0	
	Manufacturer	145h (325d)	Manufacturer ID
	Identity number	0nnn	Serial number 21 bit

Parameter Group Numbers (PGN)	Configuration data	PGN EF00h	Proprietary-A (PDU1 peer-to-peer)
	Process data	PGN FFnnh	Proprietary-B (PDU2 broadcast); nn Group Extension (PS) configurable

Specifications	Excitation voltage	8 ... 36 V DC
	Excitation current	typ. 20 mA at 24 V typ. 40 mA at 12 V max. 80 mA
	Measuring rate	1 kHz (asynchronous)
	Stability (temperature)	±50 x 10 ⁻⁶ / °C f.s.
	Repeatability	1 LSB
	Operating temperature	See specification of the respective sensor
	Protection	Reverse polarity, short circuit
	Dielectric strength	1 kV (V AC, 50 Hz, 1 min.)
	EMC	EN 61326-1:2013

Signal wiring / connection	Signal name	Connector pin no.
	Shield	1
	Excitation +	2
	GND	3
	CAN-H	4
	CAN-L	5

View to sensor connector

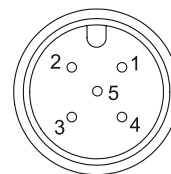

Connector cable
M12, 4 pin
Suitable for 5-pin
sensor connectors

The 4-lead shielded cable is supplied with a mating 4-pin 90° M12 connector at one end and 4 wires at the other end. Available lengths are 2 m, 5 m and 10 m. Wire: cross sectional area 0.34 mm².

Order code:

KAB - XM - M12/4F/W - LITZE

IP69K: **KAB - XM - M12/4F/W/69K - LITZE**

Length in m

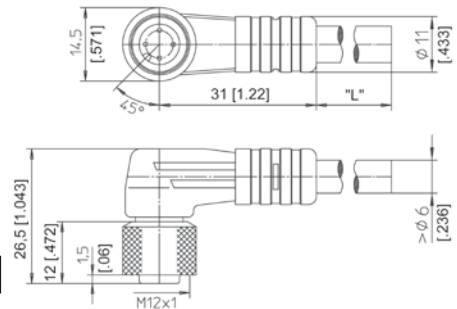

Connector cable
M12, 4 pin
Suitable for 5-pin
sensor connectors

The 4-lead shielded cable is supplied with a mating 4-pin M12 connector at one end and 4 wires at the other end. Available lengths are 2 m, 5 m and 10 m. Wire: cross sectional area 0.34 mm².

Order code:

KAB - XM - M12/4F/G - LITZE

IP69K: **KAB - XM - M12/4F/G/69K - LITZE**

Length in m

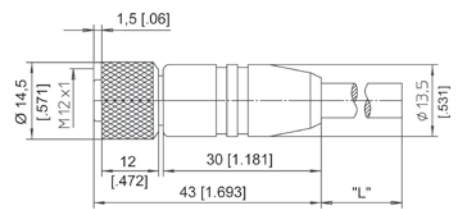

Signal wiring M12, 4 pin	Connector pin / cable color			
	1	2	3	4
	brown	white	blue	black

Connector cable
M12, 5 pin

The 5-lead shielded cable is supplied with a mating 5-pin 90° M12 connector at one end and 5 wires at the other end. Available lengths are 2 m, 5 m and 10 m. Wire: cross sectional area 0.34 mm².
Order code:

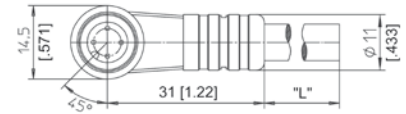

KAB - XM - M12/5F/W - LITZE

IP69K: **KAB - XM - M12/5F/W/69K - LITZE**

Length in m

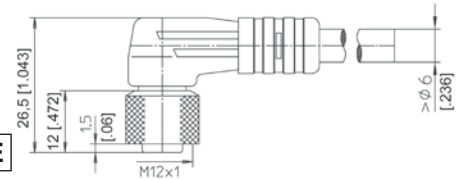

Connector cable
M12, 5 pin

The 5-lead shielded cable is supplied with a mating 5-pin M12 connector at one end and 5 wires at the other end. Available lengths are 2 m, 5 m and 10 m. Wire: cross sectional area 0.34 mm².
Order code:

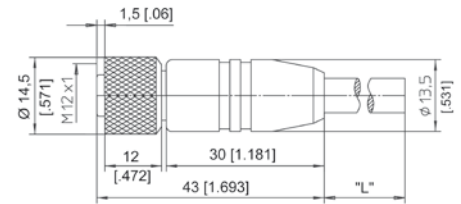

KAB - XM - M12/5F/G - LITZE

IP69K: **KAB - XM - M12/5F/G/69K - LITZE**

Length in m

Signal wiring M12, 5 pin	Connector pin / cable color				
	1	2	3	4	5
	brown	white	blue	black	grey

Connector cable
M12, 8 pin

The 8-lead shielded cable is supplied with a mating 8-pin 90° M12 connector at one end and 8 wires at the other end. Available lengths are 2 m, 5 m and 10 m. Wire: cross sectional area 0.25 mm².
Order code:

KAB - XM - M12/8F/W - LITZE
IP69K: **KAB - XM - M12/8F/W/69K - LITZE**
Length in m ↑

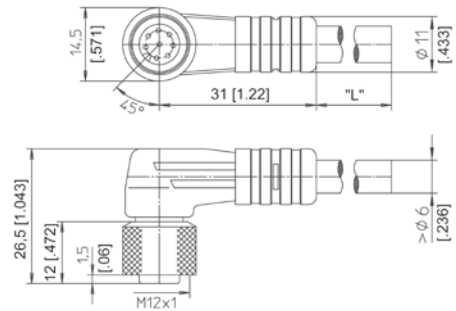

Connector cable
M12, 8 pin

The 8-lead shielded cable is supplied with a mating 8-pin M12 connector at one end and 8 wires at the other end. Available lengths are 2 m, 5 m and 10 m. Wire: cross sectional area 0.25 mm².
Order code:

KAB - XM - M12/8F/G - LITZE
IP69K: **KAB - XM - M12/8F/G/69K - LITZE**
Length in m ↑

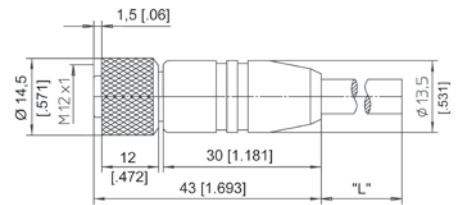

Signal wiring M12, 8 pin	Connector pin / cable color							
	1	2	3	4	5	6	7	8
	white	brown	green	yellow	grey	pink	blue	red

Connector/bus cable
M12, 5 pin
CAN bus

The 5-lead shielded cable is supplied with a female 5-pin M12 connector at one end and a male 5-pin M12 connector at the other end. Available lengths are 0.3, 2, 5 and 10 m.

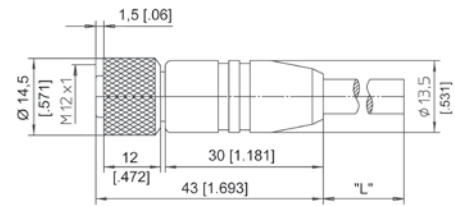

Order code:

KAB - XM - M12/5F/G - M12/5M/G - CAN

IP69K: **KAB - XM - M12/5F/G/69K - M12/5M/G/69K - CAN**

Length in m

T-piece for bus cable
M12, 5 pin
CAN bus

Order code:

KAB - TCONN - M12/5M - 2M12/5F - CAN



Terminating resistance
5 pin M12
CAN bus

Order code:

KAB - RTERM - M12/5M/G - CAN



Tape pulley WBR1

Order code: **WBR1**

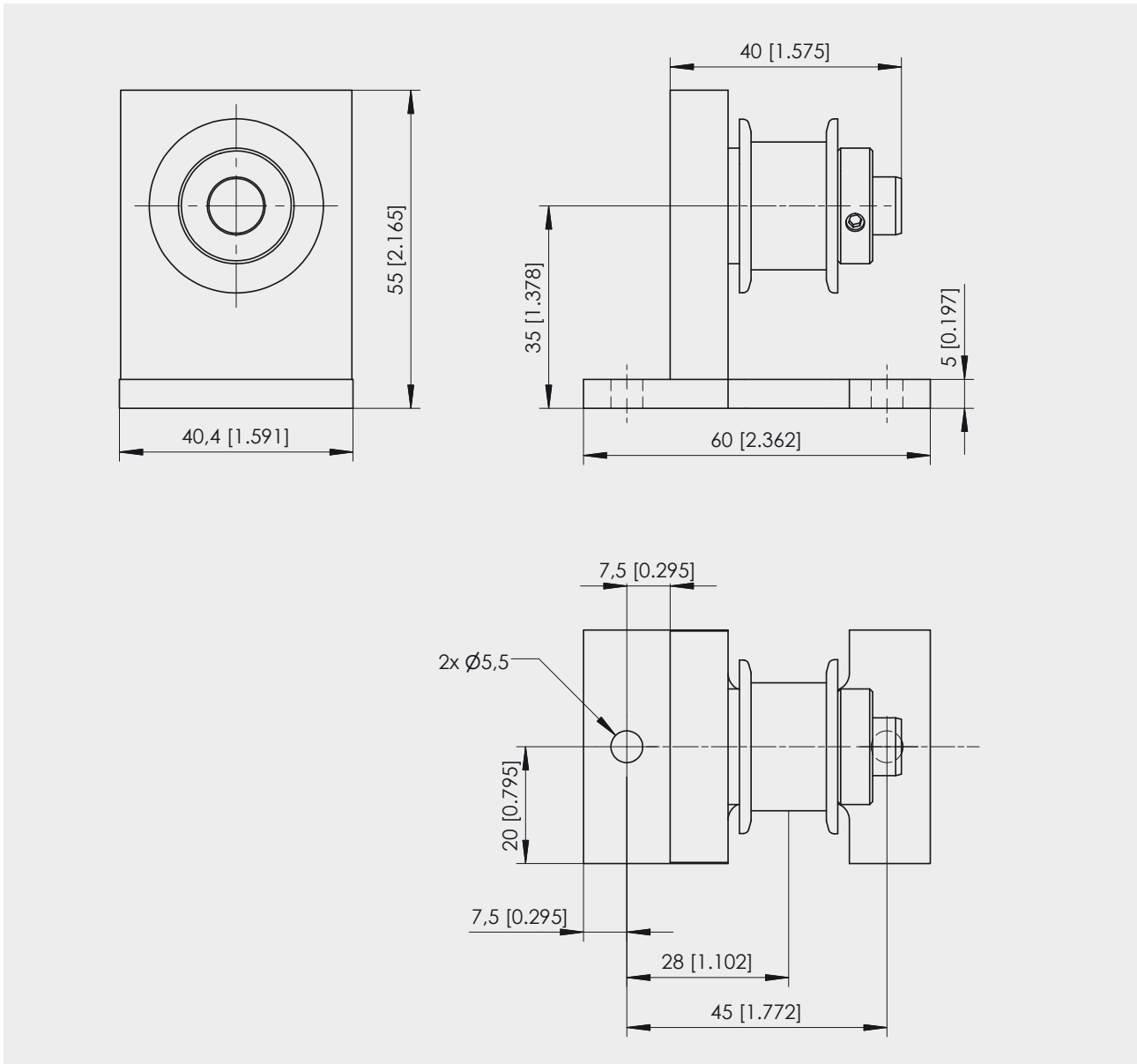

Dimensions in mm [inch]

Dimensions informative only.
For guaranteed dimensions consult factory.