

**POSITAPE®**  
**WB85**  
**Analog Output**

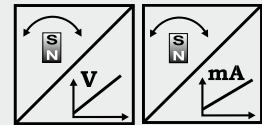

**Position sensor with measuring tape**

- Measurement range up to 6000 mm
- Protection class IP67/IP69K
- Stainless steel measuring tape
- Analog output



<b>Specifications</b>	Outputs	U2	Voltage 0.5 ... 10 V
		U8	Voltage 0.5 ... 4.5 V
		I1	Current 4 ... 20 mA, 3 wire
	Resolution		<0.05 mm
	Linearity		±0.10 % f. s.; optional ±0.05 %
	Sensing device		Magnetic absolute encoder
	Material		Plastic and stainless steel; Tape: stainless steel, 10 mm wide, 0.08 mm thick
	Protection class		IP67/IP69K (with mating connector)
	Connection		Connector M12, 5 pin
	Shock		EN 60068-2-27:1993, 100 g/11 ms, 100 shocks
	Vibration		EN 60068-2-6:1995, 20 g 10 Hz-2 kHz, 10 cycles
	EMC, temperature		Refer to output specification

**Order code WB85**



**Model name**

**Measurement range (in mm)**

5000 / 6000

**Output**

- U2 = 0.5 ... 10 V signal conditioner
- U8 = 0.5 ... 4.5 V signal conditioner
- I1 = 4 ... 20 mA signal conditioner

**Signal characteristics**

- A = increasing (eg. 4 ... 20 mA)
- D = decreasing (eg. 20 ... 4 mA)

**Linearity**

- L10 = ±0.10 % (standard)
- L05 = ±0.05 % (optional)

**Connection**

M12R5 = Connector M12, 5 pin

**Dust wiper**

BAB1

Order code connector cable see page 13

**Order example: WB85 - 6000 - I1 - A - L10 - M12R5 - BAB1**

# POSITAPE®

## WB85

### Analog Output, programmable

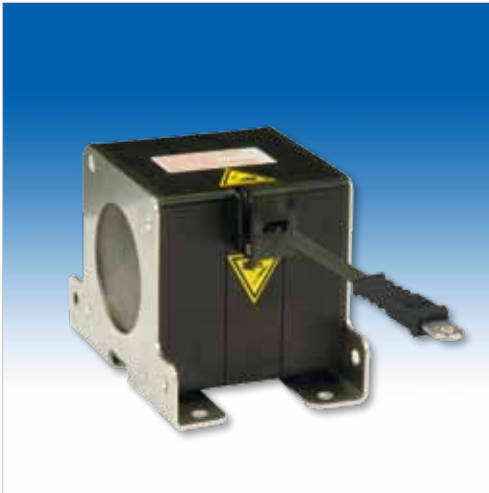

#### Position sensor with measuring tape

- Measurement range up to 6000 mm
- Protection class IP67/IP69K
- Stainless steel measuring tape
- Analog output, programmable

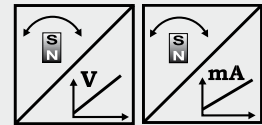

Specifications	Outputs	U2/PMU	Voltage 0.5 ... 10 V, programmable
		U8/PMU	Voltage 0.5 ... 4.5 V, programmable
	I1/PMU	Current 4 ... 20 mA, 3 wire, programmable	
	Resolution		<0.05 mm
	Linearity		±0.10 % f. s.; optional ±0.05 %
	Sensing device		Magnetic absolute encoder
	Material		Plastic and stainless steel; Tape: stainless steel, 10 mm wide, 0.08 mm thick
	Protection class		IP67/IP69K (with mating connector)
	Connection		Connector M12, 5 pin
	Shock		EN 60068-2-27:1993, 100 g/11 ms, 100 shocks
	Vibration		EN 60068-2-6:1995, 20 g 10 Hz-2 kHz, 10 cycles
	EMC, temperature		Refer to output specification

#### Order code WB85

WB85 - [ ] - [ ] - [ ] - [ ] - [ ] - [ ] - BAB1

#### Model name

#### Measurement range (in mm)

5000 / 6000

#### Output

U2/PMU = 0.5 ... 10 V signal conditioner, programmable  
 U8/PMU = 0.5 ... 4.5 V signal conditioner, programmable  
 I1/PMU = 4 ... 20 mA signal conditioner, programmable

#### Signal characteristics

A = increasing (eg. 4 ... 20 mA)  
 D = decreasing (eg. 20 ... 4 mA)

#### Linearity

L10 = ±0.10 % (standard)  
 L05 = ±0.05 % (optional)

#### Connection

M12R5 = Connector M12, 5 pin

#### Dust wiper

BAB1

Order code connector cable see page 14

Order example: WB85 - 6000 - U2/PMU - A - L10 - M12R5 - BAB1



**Position sensor with measuring tape**

- Measurement range up to 6000 mm
- Protection class IP67/IP69K
- Stainless steel measuring tape
- Analog output, redundant

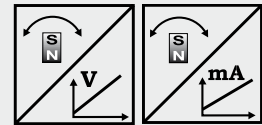

<b>Specifications</b>	Outputs	U2R	Voltage 0.5 ... 10 V, redundant
		U8R	Voltage 0.5 ... 4.5 V, redundant
		I1R	Current 4 ... 20 mA, 3 wire, redundant
	Resolution		<0.05 mm
	Linearity		±0.10 % f. s.; optional ±0.05 %
	Sensing device		Magnetic absolute encoder
	Material		Plastic and stainless steel; Tape: stainless steel, 10 mm wide, 0.08 mm thick
	Protection class		IP67/IP69K (with mating connector)
	Connection		Connector M12, 8 pin
	Shock		EN 60068-2-27:1993, 100 g/11 ms, 100 shocks
	Vibration		EN 60068-2-6:1995, 20 g 10 Hz-2 kHz, 10 cycles
	EMC, temperature		Refer to output specification

**Order code WB85**



**Model name**

**Measurement range (in mm)**

5000 / 6000

**Output**

U2R = 0.5 ... 10 V signal conditioner, redundant

U8R = 0.5 ... 4.5 V signal conditioner, redundant

I1R = 4 ... 20 mA signal conditioner, redundant

**Signal characteristics**

A/A = Output 1 increasing, output 2 increasing

A/D = Output 1 increasing, output 2 decreasing

D/D = Output 1 decreasing, output 2 decreasing

**Linearity**

L10 = ±0.10 % (standard)

L05 = ±0.05 % (optional)

**Connection**

M12R8 = Connector M12, 8 pin

**Dust wiper**

BAB1

Order code connector cable see page 15

**Order example: WB85 - 6000 - I1R - A/D - L10 - M12R8 - BAB1**



**Position sensor with measuring tape**

- Measurement range up to 6000 mm
- Protection class IP67/IP69K
- Stainless steel measuring tape
- Digital output SSI

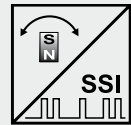

Specifications		
Output	Synchronous serial interface (SSI)	
Resolution	0.05 mm	
Linearity	±0.10 % f.s.; optional ±0.05 %	
Sensing device	Magnetic absolute encoder	
Material	Plastic and stainless steel; Tape: stainless steel, 10 mm wide, 0.08 mm thick	
Protection class	IP67/IP69K (with mating connector)	
Connection	Connector M12, 8 pin	
Shock	EN 60068-2-27:1993, 100 g/11 ms, 100 shocks	
Vibration	EN 60068-2-6:1995, 20 g 10 Hz-2 kHz, 10 cycles	
EMC, temperature	Refer to output specification	

**Order code WB85**

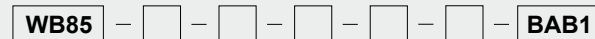

- Model name**
- Measurement range (in mm)**  
6000
- Resolution (in µm)**  
50 (other resolutions on demand)
- Output**  
MSSI = SSI synchronous serial interface
- Linearity**  
L10 = ±0.10%  
L05 = ±0.05% (optional)
- Connection**  
M12R8 = Connector M12, 8 pin
- Dust wiper**  
BAB1

Order code connector cable see page 15

**Order example: WB85 - 6000 - 50 - MSSI - L10 - M12R8 - BAB1**



**Position sensor with measuring tape**

- Measurement range up to 6000 mm
- Protection class IP67/IP69K
- Stainless steel measuring tape
- Digital output CANopen or CAN SAE J1939
- Optional redundant CAN Bus (on demand)

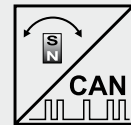

Specifications	Output	CANopen or CAN SAE J1939
	Resolution	setting via CAN Bus
	Linearity	±0.10 % f.s.; optional ±0.05 %
	Sensing device	Magnetic absolute encoder
	Material	Plastic and stainless steel; Tape: stainless steel, 10 mm wide, 0.08 mm thick
	Protection class	IP67/IP69K (with mating connector)
	Connection	Connector M12, 5 pin
	Shock	EN 60068-2-27:1993, 100 g/11 ms, 100 shocks
	Vibration	EN 60068-2-6:1995, 20 g 10 Hz-2 kHz, 10 cycles
	EMC, temperature	Refer to output specification

**Bestellcode WB85**



**Model name**

**Measurement range (in mm)**

6000

**Output**

MCANOP = CANopen

MCANJ1939 = CAN SAE J1939

**Linearity**

L10 = 0.10%

L05 = 0.05% (optional)

**Connection**

M12/CAN = Connector M12, 5 pin

**Dust wiper**

BAB1

Order code connector cable see page 16

**Order example: WB85 - 6000 - MCANOP - L10 - M12/CAN - BAB1**

Dimensions WB85

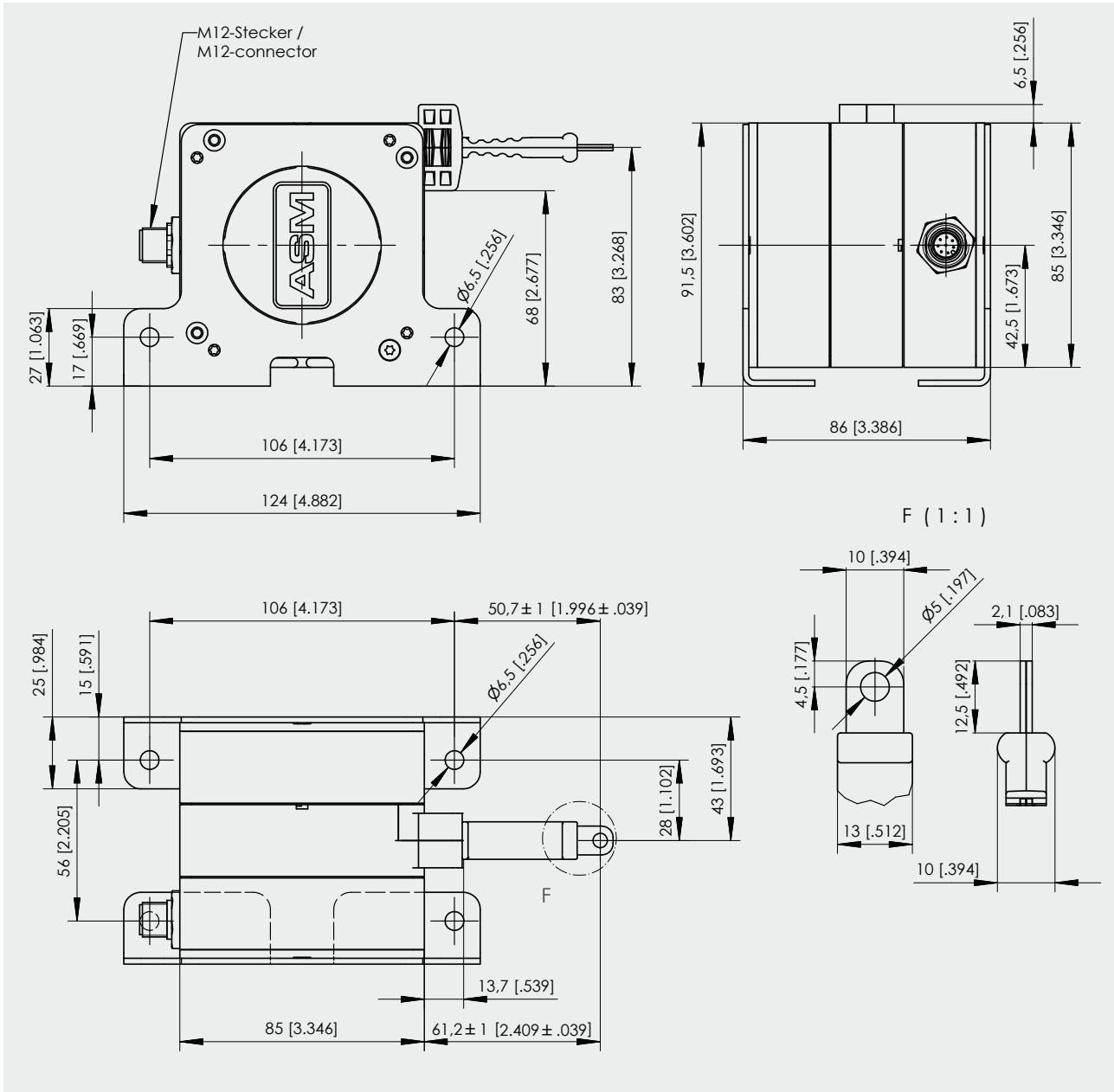

Dimensions in mm [inch]

Dimensions informative only.  
For guaranteed dimensions consult factory.

# POSITAPE®

## U2, U8 and I1

### Analog output

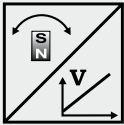

<b>U2</b> Voltage output 0.5 ... 10 V 	Excitation voltage	10 ... 36 V DC
	Excitation current	typ. 20 mA at 24 V DC typ. 20 mA at 24 V DC max. 60 mA
	Output voltage	0,5 ... 10 V DC
	Output current	2 mA max.
	Measuring rate	1 kHz standard
	Stability (temperature)	$\pm 50 \times 10^{-6}/^{\circ}\text{C}$ f.s. (typical)
	Protection	Reverse polarity, short circuit
	Operating temperature	-40 ... +85 °C
	EMC	EN61326-1:2006

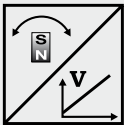
<b>U8</b> Voltage output 0.5 ... 4.5 V 	Excitation voltage	10 ... 36 V DC
	Excitation current	typ. 17 mA at 24 V DC typ. 32mA at 12 V DC max. 60 mA
	Output voltage	0,5 ... 4,5 V DC
	Output current	2 mA max.
	Measuring rate	1 kHz standard
	Stability (temperature)	$\pm 50 \times 10^{-6}/^{\circ}\text{C}$ f.s. (typical)
	Protection	Reverse polarity, short circuit
	Operating temperature	-40 ... +85 °C
	EMC	EN61326-1:2006

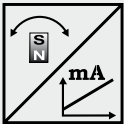
<b>I1</b> Current output 4 ... 20 mA, 3 wire 	Excitation voltage	10 ... 36 V DC
	Excitation current	typ. 36 mA at 24 V DC typ. 70 mA at 12 V DC max. 100 mA
	Load $R_L$	500 $\Omega$ max.
	Output current	4 ... 20 mA
	Measuring rate	1 kHz standard
	Stability (temperature)	$\pm 50 \times 10^{-6}/^{\circ}\text{C}$ f.s. (typical)
	Protection	Reverse polarity, short circuit
	Operating temperature	-40 ... +85 °C
	EMC	EN61326-1:2006

### Output signals

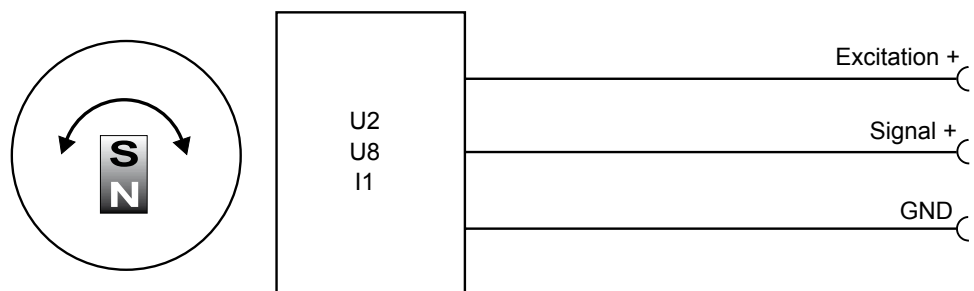

Signal wiring/ connection	Output signal	Connector pin	Cable wire color
	Excitation +	1	brown
	Signal	2	white
	GND	3	blue
	Do not connect!	4	black
	Do not connect!	5	(grey)

View to sensor  
connector

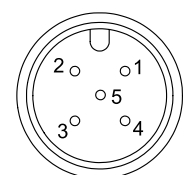

<b>U2/PMU</b> Voltage output 0.5 ... 10 V 	Excitation voltage	10 ... 36 V DC
	Excitation current	typ. 20 mA at 24 V DC, typ. 38 mA at 12 V DC max. 60 mA
	Output voltage	0,5 ... 10 V DC
	Output current	2 mA max.
	Measuring rate	1 kHz standard
	Stability (temperature)	$\pm 50 \times 10^{-6}/^{\circ}\text{C}$ f.s. (typical)
	Protection	Reverse polarity, short circuit
	Operating temperature	-40 ... +85 °C
	EMC	EN61326-1:2006
	<b>U8/PMU</b> Voltage output 0.5 ... 4.5 V 	Excitation voltage
Excitation current		typ. 17 mA at 24 V DC, typ. 32 mA at 12 V DC max. 60 mA
Output voltage		0,5 ... 4,5 V DC
Output current		2 mA max.
Measuring rate		1 kHz standard
Stability (temperature)		$\pm 50 \times 10^{-6}/^{\circ}\text{C}$ f.s. (typical)
Protection		Reverse polarity, short circuit
Operating temperature		-40 ... +85 °C
EMC		EN61326-1:2006
<b>I1/PMU</b> Current output 4 ... 20 mA, 3 wire 		Excitation voltage
	Excitation current	typ. 36 mA at 24 V DC, typ. 70 mA at 12 V DC max. 100 mA
	Load $R_L$	500 $\Omega$ max.
	Output current	4 ... 20 mA
	Measuring rate	1 kHz standard
	Stability (temperature)	$\pm 50 \times 10^{-6}/^{\circ}\text{C}$ f.s. (typical)
	Protection	Reverse polarity, short circuit
	Operating temperature	-40 ... +85 °C
	EMC	EN61326-1:2006

Output signals

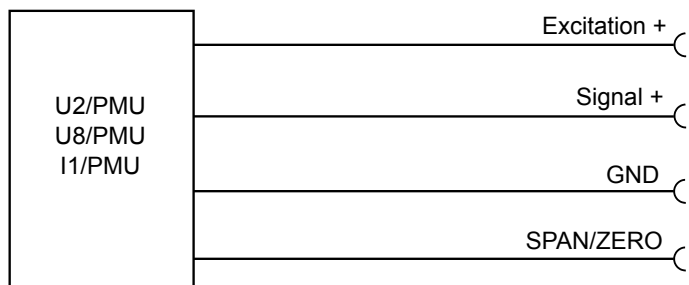
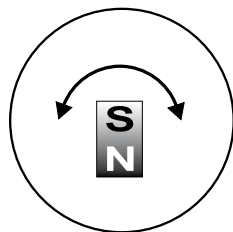

Signal wiring/ connection	Signal	Connector pin	Cable wire color
	Excitation +	1	brown
	Signal	2	white
	GND	3	blue
	Do not connect!	4	black
	SPAN/ZERO	5	grey

View to sensor connector

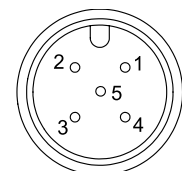

Option -PMU

Programming of the start and end value by the customer

Teach-In of start and end value for the options U2/PMU, I1/PMU, U8/PMU is provided by a binary signal SPAN/ZERO. At the start position connect signal SPAN/ZERO for a period of 2 ... 3 seconds to GND via push button. At the end position connect signal SPAN/ZERO for a period of 5 ... 6 seconds to GND via a push button. The taughted positions will be stored non-volatile.

To reset the sensor to factory default signal ZERO/END must be connected to ground while powering up the sensor for 2 ... 3 seconds.



<b>U2R</b> Voltage output 0.5 ... 10 V 	Excitation voltage	10 ... 36 V DC
	Excitation current	typ. 22 mA at 24 V DC typ. 43mA at 12 V DC max. 60 mA per channel
	Output voltage	0,5 ... 10 V DC
	Output current	2 mA max.
	Measuring rate	1 kHz standard
	Stability (temperature)	$\pm 50 \times 10^{-6}/^{\circ}\text{C}$ f.s. (typical)
	Protection	Reverse polarity, short circuit
	Operating temperature	-40 ... +85 °C
	EMC	EN61326-1:2006

<b>U8R</b> Voltage output 0.5 ... 4,5 V 	Excitation voltage	10 ... 36 V DC
	Excitation current	typ. 20mA at 24 V DC typ. 38mA at 12 V DC max. 60 mA per channel
	Output voltage	0,5 ... 4,5 V DC
	Output current	2 mA max.
	Measuring rate	1 kHz standard
	Stability (temperature)	$\pm 50 \times 10^{-6}/^{\circ}\text{C}$ f.s. (typical)
	Protection	Reverse polarity, short circuit
	Operating temperature	-40 ... +85 °C
	EMC	EN61326-1:2006

<b>I1R</b> Current output 4 ... 20 mA, 3 wire 	Excitation voltage	10 ... 36 V DC
	Excitation current	typ. 39 mA at 24 V DC typ. 76 mA at 12 V DC max. 100 mA per channel
	Load $R_L$	500 $\Omega$ max.
	Output current	4 ... 20 mA
	Measuring rate	1 kHz standard
	Stability (temperature)	$\pm 50 \times 10^{-6}/^{\circ}\text{C}$ f.s. (typical)
	Protection	Reverse polarity, short circuit
	Operating temperature	-40 ... +85 °C
	EMC	EN61326-1:2006

Output signals

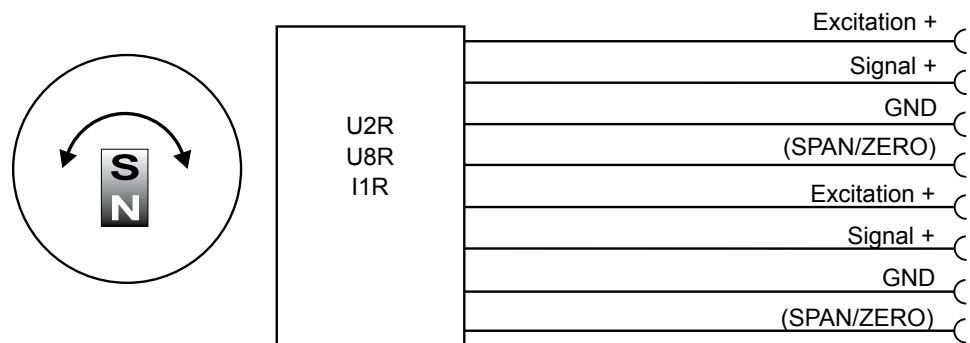

Signal wiring/ connection	Channel	Signal	Connector Pin	Cable wire color
	1	Excitation +	1	white
	1	Signal	2	brown
	1	GND	3	green
	1	SPAN/ZERO (Option PMU)	4	yellow
	2	Excitation +	5	grey
	2	Signal	6	pink
	2	GND	7	blue
	2	SPAN/ZERO (Option PMU)	8	red

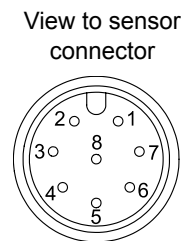

<b>MSSI</b> Synchronous serial SSI 	Interface	EIA RS-422
	Excitation voltage	8 ... 36 V DC
	Excitation current	typ. 19 mA at 24 V DC typ. 35 mA at 12 V DC max. 80 mA
	Clock frequency	100 kHz ... 500 kHz
	Code	Gray-Code, continuous progression
	Delay between pulse trains	20 µs min.
	Stability (temperature)	$\pm 50 \times 10^{-6}$ / °C f.s. (typical)
	Operating temperature	-40 ... +85 °C
	Protection	Short circuit
	EMC	EN61326-1:2006

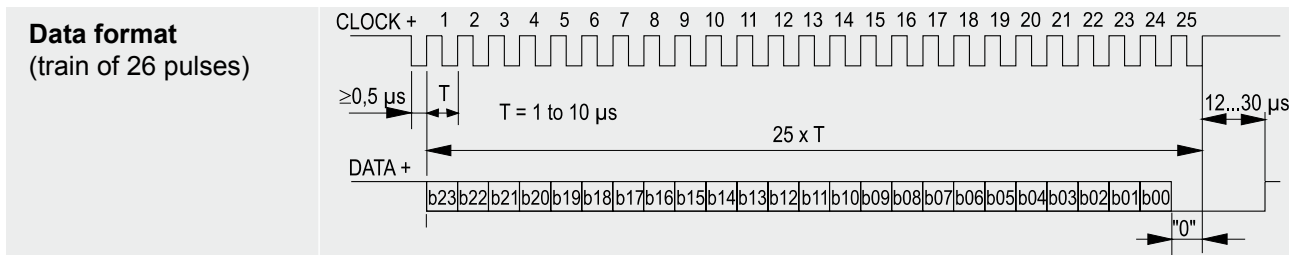

**Recommended processing circuit**

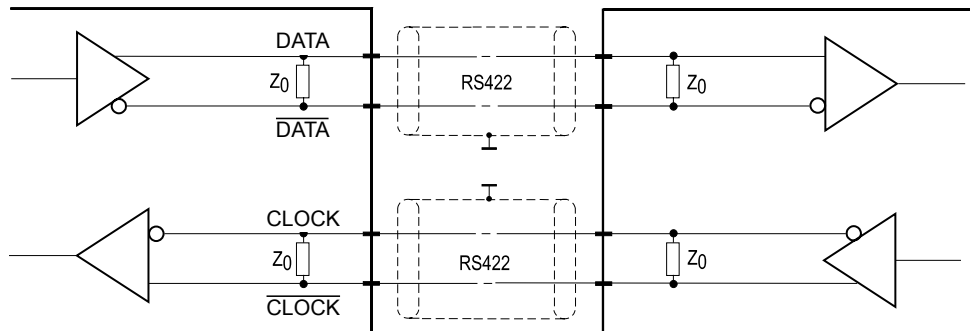



Transmission rate	Cable length	Baud rate
	50 m	100-400 kHz
	100 m	100-300 kHz

**Note:**  
 Extension of the cable length will reduce the maximum transmission rate.

Signal wiring/ Connection	Signal	Connector Pin	Cable wire color
	Excitation +	1	white
	Excitation GND	2	brown
	CLOCK	3	green
	CLOCK	4	yellow
	DATA	5	grey
	DATA	6	pink
	-	7	blu
	-	8	red

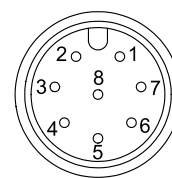
View to sensor connector





<b>MCANOP</b> CANopen 	Communication profile	CANopen CiA 301 V 4.02, Slave
	Encoder profile	Encoder CiA 406 V 3.2
	Error Control	Node Guarding, Heartbeat, Emergency Message
	Node ID	Adjustable via LSS; default: 127
	PDO	3 TxPDO, 0 RxPDO, no linking, static mapping
	PDO Modes	Event-/Time triggered, Remote-request, Sync cyclic/acyclic
	SDO	1 server, 0 client
	CAM	2 cams
	Certified	Yes
	Transmission rates	50 kbit to 1 Mbit, adjustable via LSS; default: 125 kbit
	Bus connection	M12 connector, 5 pins
	Integrated bus terminating resistor	120Ω adjustable by the customer
	Bus, galvanic isolated	No

<b>Specifications</b>	Excitation voltage	8 ... 36 V DC
	Excitation current	typ. 20 mA at 24 V DC typ. 40 mA at 12 V DC max. 80 mA
	Measuring rate	1 kHz (asynchronous)
	Stability (temperature)	±50 x 10 <sup>-6</sup> / °C f.s.
	Repeatability	1 LSB
	Operating temperature	-40 ... +85 °C
	Protection	Reverse polarity, short circuit
	Dielectric strength	1 kV (V AC, 50 Hz, 1 min.)
	EMC	EN 61326-1:2006

<b>Signal wiring / connection</b>	Signal	Connector pin
	Shield	1
	Excitation +	2
	GND	3
	CAN-H	4
	CAN-L	5

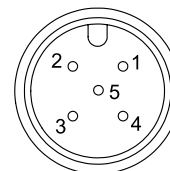
View to sensor connector



<b>MCANJ1939</b> CAN SAE J1939 	CAN specification	ISO 11898, Basic and Full CAN 2.0 B
	Transceiver	24V-compliant, not isolated
	Communication profile	SAE J1939
	Baud rate	250 kbit/s
	Integrated bus terminating resistor	120Ω adjustable by the customer
	Address	Default 247d, configurable

<b>NAME Fields</b>	Arbitrary address capable	1	Yes
	Industry group	0	Global
	Vehicle system	7Fh (127d)	Non specific
	Vehicle system instance	0	
	Function	FFh (255d)	Non specific
	Function instance	0	
	ECU instance	0	
	Manufacturer	145h (325d)	Manufacturer ID
	Identity number	0nnn	Serial number 21 bit

<b>Parameter Group Numbers (PGN)</b>	Configuration data	PGN EF00h	Proprietary-A (PDU1 peer-to-peer)
	Process data	PGN FFnnh	Proprietary-B (PDU2 broadcast); nn Group Extension (PS) configurable

<b>Specifications</b>	Excitation voltage	8 ... 36 V DC
	Excitation current	typ. 20 mA at 24 V DC typ. 40 mA at 12 V DC max. 80 mA
	Measuring rate	1 kHz (asynchronous)
	Stability (temperature)	±50 x 10 <sup>-6</sup> / °C f.s.
	Repeatability	1 LSB
	Operating temperature	-20 ... +105 °C
	Protection	Reverse polarity, short circuit
	Dielectric strength	1 kV (V AC, 50 Hz, 1 min.)
	EMC	EN 61326-1:2006

<b>Signal wiring / connection</b>	<b>Signal name</b>	<b>Connector pin no.</b>
	Shield	1
	Excitation +	2
	GND	3
	CAN-H	4
	CAN-L	5

View to sensor connector

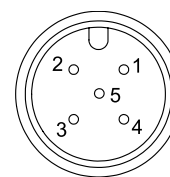

**Connector cable**  
 4 pin M12

Suitable for 5-pin sensor connectors

The 4-lead shielded cable is supplied with a mating 4-pin 90° M12 connector at one end and 4 wires at the other end. Available lengths are 2, 5 and 10 m. Wire: cross sectional area 0.34 mm<sup>2</sup>.  
 Order code:

**KAB - XM - M12/4F/W - LITZE**

IP69K: **KAB - XM - M12/4F/W/69K - LITZE**

Length in m

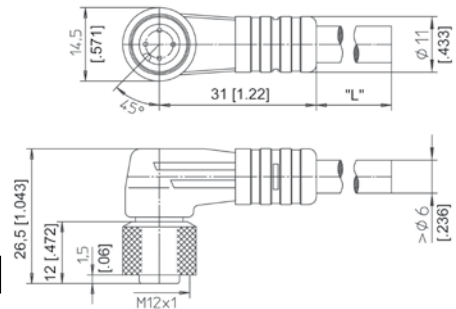

**Connector cable**  
 4 pin M12

Suitable for 5-pin sensor connectors

The 4-lead shielded cable is supplied with a mating 4-pin M12 connector at one end and 4 wires at the other end. Available lengths are 2, 5 and 10 m. Wire: cross sectional area 0.34 mm<sup>2</sup>.  
 Order code:

**KAB - XM - M12/4F/G - LITZE**

IP69K: **KAB - XM - M12/4F/G/69K - LITZE**

Length in m

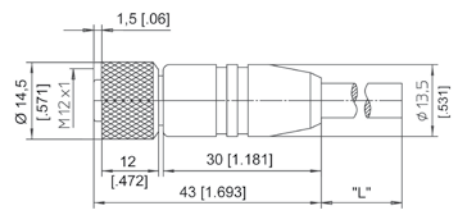

Signal wiring M12, 4 pin	Connector pin / cable color			
	1	2	3	4
brown	white	blue	black	

**Connector cable**  
 5 pin M12

The 5-lead shielded cable is supplied with a mating 5-pin 90° M12 connector at one end and 5 wires at the other end. Available lengths are 2, 5 and 10 m. Wire: cross sectional area 0.34 mm<sup>2</sup>.  
 Order code:

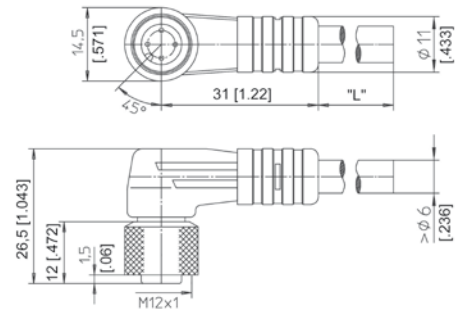

**KAB - XM - M12/5F/W - LITZE**

IP69K: **KAB - XM - M12/5F/W/69K - LITZE**

Length in m ↑

**Connector cable**  
 5 pin M12

The 5-lead shielded cable is supplied with a mating 5-pin M12 connector at one end and 5 wires at the other end. Available lengths are 2, 5 and 10 m. Wire: cross sectional area 0.34 mm<sup>2</sup>.  
 Order code:

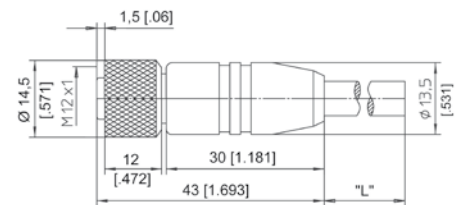

**KAB - XM - M12/5F/G - LITZE**

IP69K: **KAB - XM - M12/5F/G/69K - LITZE**

Length in m ↑

Signal wiring M12, 5 pin	Connector pin / cable color				
	1	2	3	4	5
brown	white	blue	black	grey	

**Connector cable**  
 8 pin M12

The 8-lead shielded cable is supplied with a mating 8-pin 90° M12 connector at one end and 8 wires at the other end. Available lengths are 2, 5 and 10 m. Wire: cross sectional area 0.25 mm².  
 Order code:

**KAB - XM - M12/8F/W - LITZE**  
 IP69K: **KAB - XM - M12/8F/W/69K - LITZE**  
 Length in m ↑

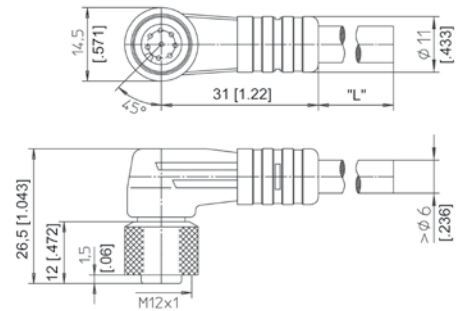

**Connector cable**  
 8 pin M12

The 8-lead shielded cable is supplied with a mating 8-pin M12 connector at one end and 8 wires at the other end. Available lengths are 2, 5 and 10 m. Wire: cross sectional area 0.25 mm².  
 Order code:

**KAB - XM - M12/8F/G - LITZE**  
 IP69K: **KAB - XM - M12/8F/G/69K - LITZE**  
 Length in m ↑

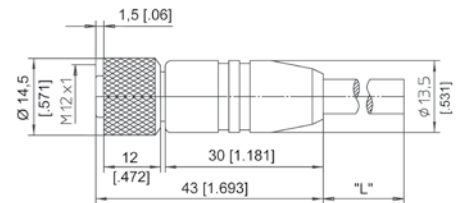

Signal wiring M12, 8 pin	Connector pin / cable color							
	1	2	3	4	5	6	7	8
	white	brown	green	yellow	grey	pink	blue	red

**Connector/bus cable**  
 5 pin M12  
 CAN bus

The 5-lead shielded cable is supplied with a female 5-pin M12 connector at one end and a male 5-pin M12 connector at the other end. Available lengths are 0.3, 2, 5 and 10 m.

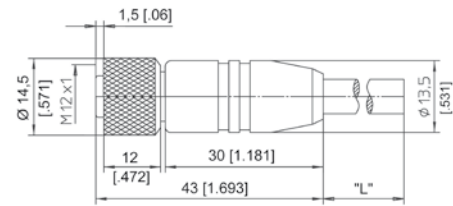

Order code:

**KAB - XM - M12/5F/G - M12/5M/G - CAN**

IP69K: **KAB - XM - M12/5F/G/69K - M12/5M/G/69K - CAN**

Length in m ↑

**T-piece for bus cable**  
 5 pin M12  
 CAN bus

Order code:

**KAB - TCONN - M12/5M - 2M12/5F - CAN**



**Terminating resistance**  
 5 pin M12  
 CAN bus

Order code:

**KAB - RTERM - M12/5M/G - CAN**





**Tape pulley WBR1**

Order code: **WBR1**

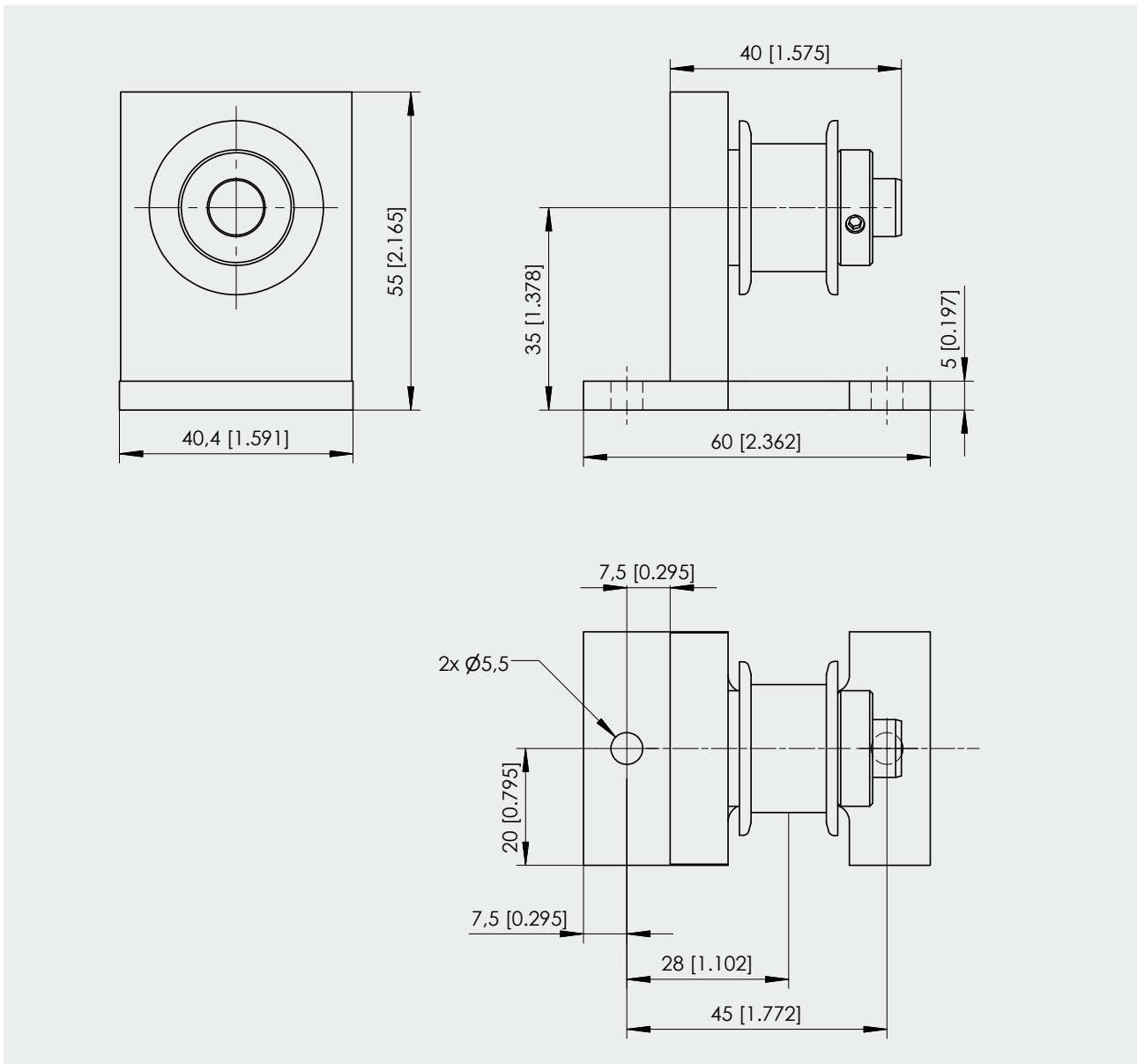

Dimensions in mm [inch]

Dimensions informative only.  
For guaranteed dimensions consult factory.