

Measuring transducers

F 400 transducers for frequency

F 400 transducers are constructed for measuring frequency in AC-nets. They can also be used for measuring pulse frequency from different types of pulse transmitters for e.g. revolution readings.

The transducers work with auxiliary power and have galvanic separation between input, output and power supply.

The transducers in plastic case are mounted directly on profiled bar 35 EN 50022. Connection to selfopening clamps for max 6 mm² wires. Transducers for mounting in 19" racks can be delivered in different application types (see special leaflet). The rack modules are 8 TE wide and in a 19" rack is place for 10 modules.

The transducers are manufactured according to IEC688.

Order facts:

Enclosed for mounting on profiled bar 35 EN 50022	19" rack modul (wide 8 TE)		External resistans
Typ	Typ		
F 400L-151	F 400R-151	0 -5, ± 5 mA	0-3000 Ω
F 400L-152	F 400R-152	0 -10, ± 10 mA	0-1500 Ω
F 400L-153	F 400R-153	0 -20, ± 20 mA	0- 750 Ω
F 400L-154	F 400R-154	4 -20 mA	0- 750 Ω
F 400L-155	F 400R-155	0 -10, ± 10 V	> 700 Ω

Order form:

Measuring transducer **F 400L-154**
 Connection 110 V
 Measuring range 45-55 Hz
 Output 4-20 mA
 Power supply 24-130 VDC
 Enclosed for mounting on profile bar 35 EN 50022

F400-FA



F400-FB

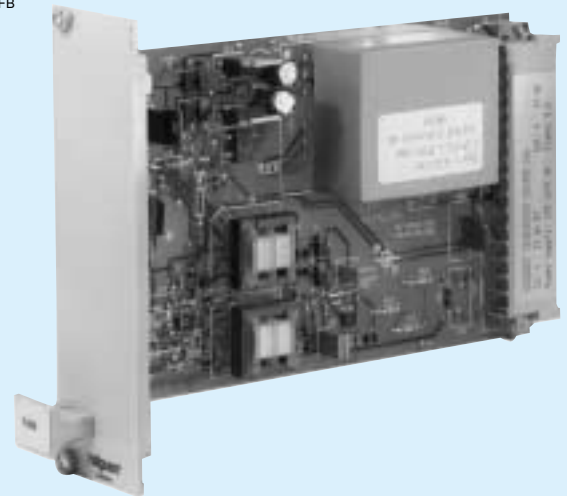

Technical data

Input

Voltage any value between 10 and 500 V (rackversion max 300 V)
 Tolerans 50 to 150% of rated voltage, max 650 V (rackversion max 325 V)
 Measuring range 15-2400 Hz, min. span. 4 Hz
 Consumption (burden) $U_{in} \times 1 \text{ mA}$, VA
 Overload capacity $1,5 \times U_{in}$ continuous
 $2 \times U_{in}$ for 10 s

Output

Output signal (span) min 0-1 mA
 max 0-20 mA
 Range 0...5/10/20 mA, 4-20 mA
 Load max 15 V
 Current limitation < 30 mA
 Voltage 0-10 V
 Burden > 700 Ω
 Ripple < 1% p.p.

General data

Accuracy class < 0,05% of nom. frequency
 < 0,5% of measured span
 Linearity error < 0,1%
 Response time 0-90% < 300 ms
 Temperature influence < 0,1%/10°C
 Temperature range 25. ..+60°C operation
 -40...+70°C storage
 Test voltage 5,6 kV, 50 Hz, 1 min
 (rackversion 3,7 kV)
 Power supply 24, 110, 230 VAC ±15%, 47-70 Hz, ca 2 VA
 24-130 VDC ±20%, ca 2,5 W
 Weight 0,4 kg
Options on request

Standards

General standards for measuring transducers EN 60688, IEC 688
 EMC emission EN 50081-2
 immunity EN 50082-2*)
 Safety IEC 61010-1, IEC 1010-1
 Inputs overvoltage cat III
 Outputs overvoltage cat II
 Pollution degree 2

*) At certain frequencies can minor deviations from class accuracy occur during the disturbance

Design

F 400 transforms a frequency to a proportional load independent DC signal.

The input signal is galvanically separated in the input transformer and fed to an impulse transformer that transforms the input signal to quartzstabilized DC voltage pulses with a constant level. The average value of these pulses is proportional to the input frequency. The pulses are filtered and fed to the output amplifier.

In case of AC the power supply is taken from a transformer which gives galvanic separation. Parts that need separate power are fed via a rectifier stage.

In case of DC power a switched unit is used which gives galvanic separation and covers the whole span 24-130 VDC.

F400-BE

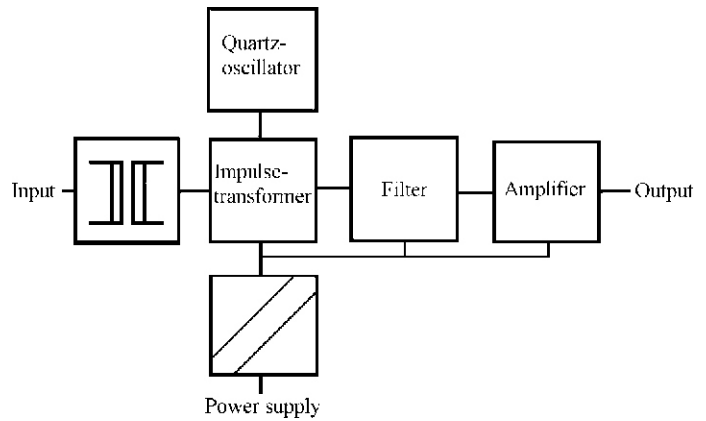

Connecting diagrams

F 400L

F400LE

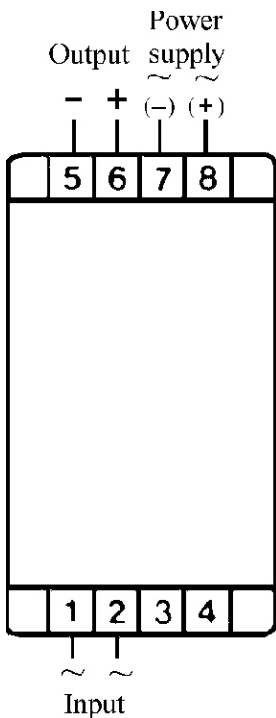

Dimensions (mm)

F 400L

MAT0MVME

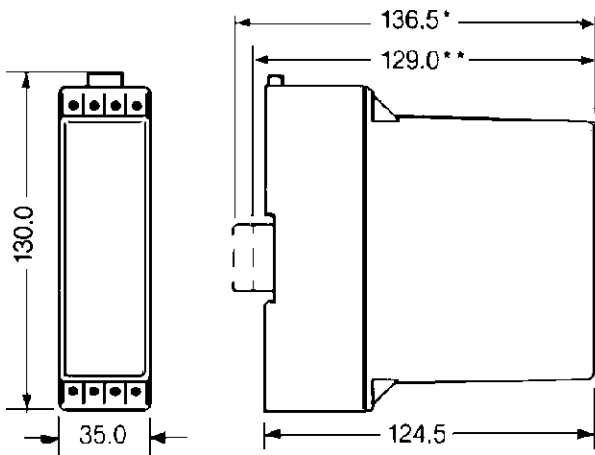

*) Profile bar 35 EN 50022, height 15 mm

***) Profile bar 35 EN 50022, height 7,5 mm

F 400R

F400RE

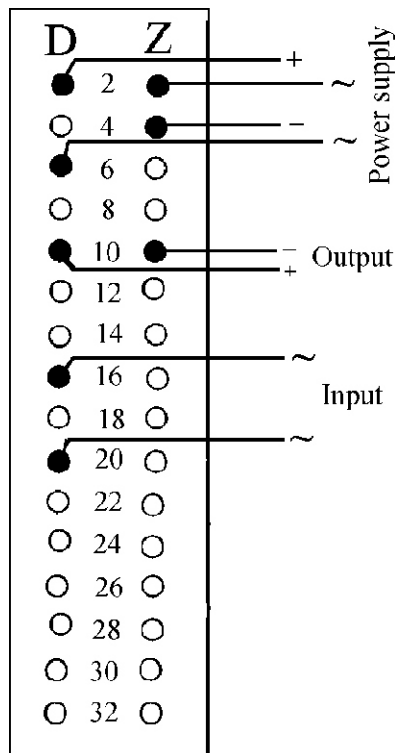

F 400R

