

Measuring transducers

VI 400 for DC current

VU 400 for DC voltage

VI 400 and VU 400 are transducers converting measured quantities of current and voltage into a proportional load independent DC signal.

The output signal can be connected to one or several receiving instruments such as panel indicators, recorders, controllers etc. The transducers have galvanic separation between in- and output and auxiliary supply.

The transducers in plastic case are mounted directly on profiled bar 35 EN 50022. Connection to selfopening clamps for max 6 mm² wires. Transducers for mounting in 19" racks can be delivered in different application types (see special leaflet). The rack modules are 8TE wide and in a 19" rack is place for 10 modules.

The transducers are manufactured according to IEC688.

Order facts:

Enclosed for mounting on profiled bar 35 EN 50022	19" rack modul (wide 8 TE)	
Type	Type	
VI 400L-15x	VI 400R-15x	
VU 400L-15x	VU 400R-15x	
Replace x with last digit for output according to table below		
Output	External resistance load	Last digit x
0 - 5 ± 5 mA	0-3000 Ω	1
0 -10 ± 10 mA	0-1500 Ω	2
0 -20 ± 20 mA	0- 750 Ω	3
4 -20 mA	0- 750 Ω	4
0 -10 ± 10 V	> 700 Ω	5

Order form:

Measuring transducer for DC voltage
 Type **VU 400L-153**
 Measuring range 0-250 VDC
 Output 0-20 mA
 Power supply 230 V, 50 Hz
 Mounting on DIN-rail

Technical data

Input VI 400

Range min 0 - 0,5 mA (± 0,25 mA)
 max 0 - 250 mA (± 250 mA)
 Input impedance voltage drop 1V (50 Ω at 20 mA)
 Overload capacity $3 \times I_{in}$ continuously, $8 \times I_{in}$, 1 s
 (max 750 mA)

Input VU 400

Range 0-60 mV to 0-500 V or ±30 mV to ±500 V
 (rack version max 300 V)
 Input impedance 10 kΩ/V
 Overload capacity $< 3 V, 3 \times U_{in}$ continuously
 $< 3 V, 10 \times U_{in}$, 1 s
 $> 3 V, 3 \times U_{in}$, 1 s

Output

Output signal (span) min 0-1 mA, max 0-20 mA
 Range 0...5/10/20, 4-20 mA
 Load max 15 V
 Current limitation < 30 mA
 Voltage 0-10 V
 Burden > 700 Ω
 Ripple < 1% p.p.

VI400FA



VI400-FB

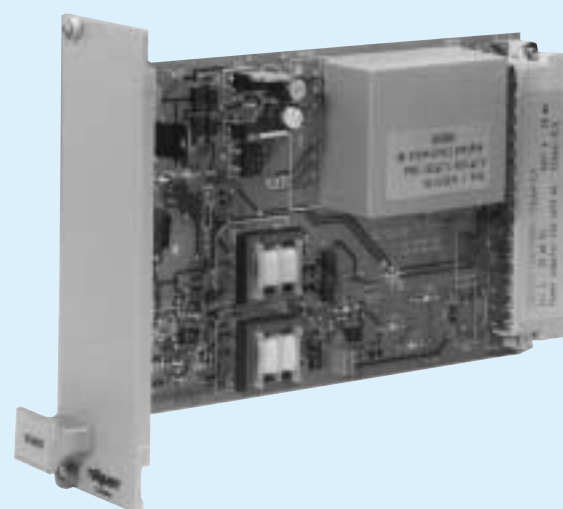

General data

Accuracy < 0,2%
 Linearity error < 0,1%
 Response time 0-90% < 30 ms
 Temperature influence < 0,1%/10°C
 Temperature range -25...+60°C operation
 -40...+70°C storage
 Test voltage 5,6 kV, 50 Hz, 1 min (rack version 3,7 kV)
 Power supply 24, 110, 230 VAC ± 15%, 47-70 Hz, ca 2 VA
 24-130 VDC ± 20%, ca 2,5 W
 Weight 0,4 kg

Options in request

Standards

General standards for measuring transducers EN 60688, IEC 688
 EMC emission EN 50081-2
 Immunity EN 50082-2¹⁾
 Safety EN 61010-1, IEC 1010-1
 Inputs overvoltage cat III
 Outputs overvoltage cat II
 Pollution degree 2

¹⁾ At certain frequencies can minor deviations from class accuracy occur during the disturbance

Design

The transducer consists of an input stage where the input signal is converted to a matching current signal that goes via a galvanic separation stage - where the signal is chopped, transformed and rectified - to the output amplifier.

The AC power supply comes from a transformer that gives a galvanic separation. Those parts that need separate power get it via a rectifying stage. The DC power comes from a switched unit that gives galvanic separation and covers the span from 24 to 130 VDC.

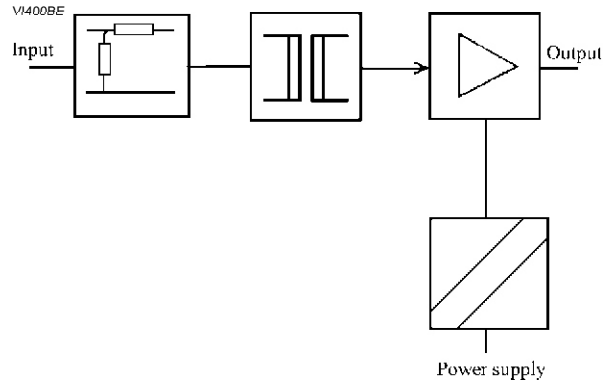

Connecting diagrams

VI/VU 400L

VI400LE



VI/VU 400R

VI400RE

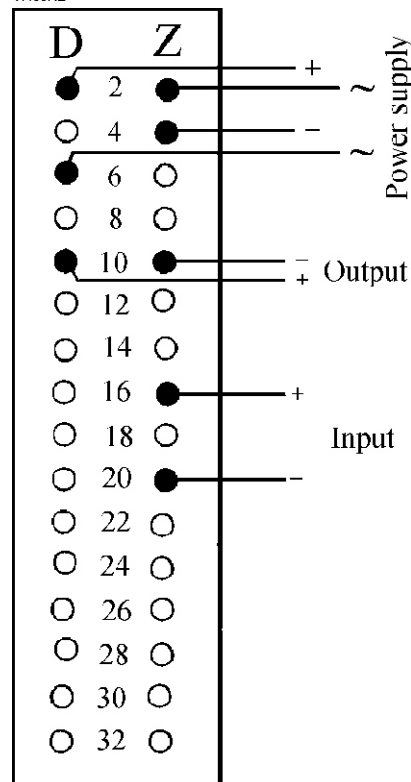

Dimensions (mm)

VI/VU 400L

MAT0MVM6

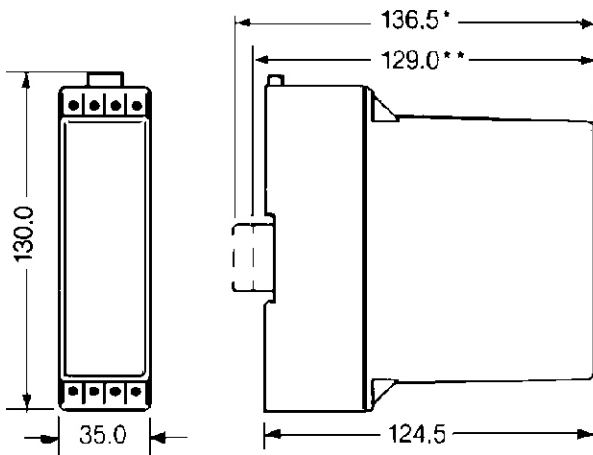

VI/VU 400R

VI400RE

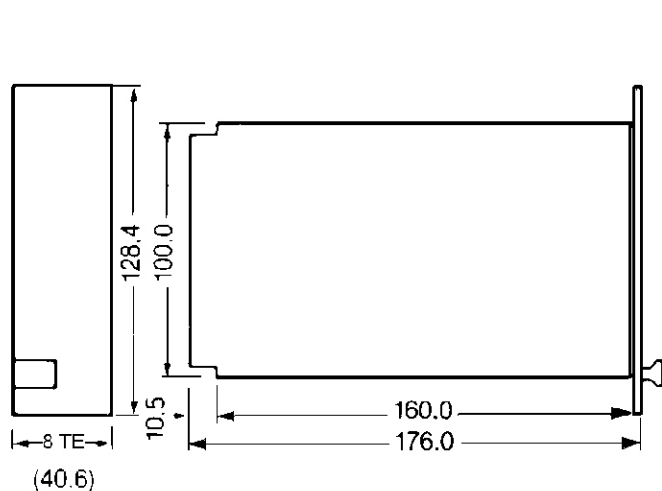

*) Profile bar 35 EN 50022, height 15 mm

***) Profile bar 35 EN 50022, height 7,5 mm