

ThermoView[®] TV40 Series

Thermal Imager Camera



Users Manual

Warranty

The manufacturer warrants this instrument to be free from defects in material and workmanship under normal use and service for the period of two years from date of purchase. This warranty extends only to the original purchaser. This warranty shall not apply to fuses, batteries or any product which has been subject to misuse, neglect, accident, or abnormal conditions of operation.

In the event of failure of a product covered by this warranty, the manufacturer will repair the instrument when it is returned by the purchaser, freight prepaid, to an authorized Service Facility within the applicable warranty period, provided manufacturer's examination discloses to its satisfaction that the product was defective. The manufacturer may, at its option, replace the product in lieu of repair. With regard to any covered product returned within the applicable warranty period, repairs or replacement will be made without charge and with return freight paid by the manufacturer, unless the failure was caused by misuse, neglect, accident, or abnormal conditions of operation or storage, in which case repairs will be billed at a reasonable cost. In such a case, an estimate will be submitted before work is started, if requested.

The foregoing warranty is in lieu of all other warranties, expressed or implied, including but not limited to any implied warranty of merchantability, fitness, or adequacy for any particular purpose or use. The manufacturer shall not be liable for any special, incidental or consequential damages, whether in contract, tort, or otherwise.

Software Warranty

The manufacturer does not warrant that the software described herein will function properly in every hardware and software environment. This software may not work in combination with modified or emulated versions of Windows operating environments, memory-resident software, or on computers with inadequate memory. The manufacturer warrants that the program disk is free from defects in material and workmanship, assuming normal use, for a period of one year. Except for this warranty, the manufacturer makes no warranty or representation, either expressed or implied, with respect to this software or documentation, including its quality, performance, merchantability, or fitness for a particular purpose. As a result, this software and documentation are licensed "as is," and the licensee (i.e., the User) assumes the entire risk as to its quality and performance. The liability of the manufacturer under this warranty shall be limited to the amount paid by the User. In no event shall the manufacturer be liable for any costs including but not limited to those incurred as a result of lost profits or revenue, loss of use of the computer software, loss of data, the cost of substitute software, claims by third parties, or for other similar costs. The manufacturer's software and documentation are copyrighted with all rights reserved. It is illegal to make copies for another person.

Disclaimer for Export Control Classification

These products are controlled under ECCN 6A003.B.4.B and an export license is needed for certain destinations. Please see RS1 controls for licensing requirements.

This manual is available in different languages. In case of differences between the language versions, the English manual is binding.

Table of Contents

Chapter	Page
TABLE OF CONTENTS	4
LIST OF TABLES	7
LIST OF FIGURES	8
COMPLIANCE STATEMENT	9
SAFETY INFORMATION	10
CONTACTS	13
1 DESCRIPTION	14
1.1 Available Models.....	15
1.2 System Architecture.....	16
2 TECHNICAL DATA	17
2.1 Measurement Specification	17
2.2 Optical Specifications	18
2.2.1 Standard Lens	18
2.3 Electrical Specifications	19
2.4 PC Specifications.....	19
2.5 Environmental Specifications	19
2.6 Dimensions	20
2.7 Scope of Delivery.....	20
3 BASICS	21
3.1 Measurement of Infrared Temperature	21
3.2 Emissivity of Target Object.....	21
4 ENVIRONMENT	22
4.1 Ambient Temperature	22
4.2 Atmospheric Quality.....	22
4.3 Protection	22
4.4 Electrical Interference	22
5 INSTALLATION	23
5.1 Positioning	23
5.2 Distance to Object	23
5.3 Focusing	23
5.4 Mounting	23
5.5 Network	24
5.6 Cabling.....	24
5.6.1 Ethernet M12 Cable.....	24
5.6.2 Power Supply Cable	26

6 OPERATION	27
6.1 GigE Vision Communication	27
6.2 LED Status Indicator	28
6.3 Shutter	29
6.4 Web Server Application	30
6.4.1 Establishing Communication	30
6.4.2 Camera Info	30
6.4.3 Camera Access	30
6.4.4 Network Configuration	31
6.4.5 Focus Control	32
6.4.6 Field of View	32
6.4.7 Temperature Unit	32
6.4.8 Emissivity	32
7 ACCESSORIES	33
7.1 Add-on Lenses	33
7.1.1 Wide Lens 0.75x	34
7.1.2 Tele Lens 2x	35
7.1.3 Tele Lens 4x	36
7.1.4 Macro	37
7.2 Electrical Accessories	38
7.2.1 Ethernet PoE Cable (A-CB-xx-M12-W08-xx)	39
7.2.2 Power Supply Cable (A-CB-xx-PS-xx)	40
7.2.3 Ethernet Cable (A-CB-LT-RJ45-25)	41
7.2.4 Ethernet Cable Short (A-CB-LT-RJ45-03)	41
7.2.5 Fiber Optic Cable (A-CB-FO-xxx)	42
7.2.6 PoE Injector (A-TV-POE1)	43
7.2.7 PoE Injector Industrial (A-TV-POE2)	44
7.2.8 Power Supply DIN Rail (A-PS-DIN-24V)	45
7.2.9 Fiber Optic to Ethernet Converter (A-CON-FO-RJ45)	46
7.2.10 Ethernet Switch (A-CON-SW)	47
7.2.11 I/O Modules	48
7.3 Mechanical Accessories	49
7.3.1 Mounting Base (A-TV-MB)	50
7.3.2 Air Purge Collar (A-TV-AP)	51
7.3.3 Water Cooling Enclosure (A-TV-AP-WC)	53
7.3.4 Protective Enclosure (A-TV-WC)	55
7.3.4.1 Air Barrier	55
7.3.4.2 Specification	56
7.3.4.3 Installation	57
7.3.5 Outdoor Enclosure (A-TV-ENC)	61
7.3.5.1 Specification	61
7.3.5.2 Installation	62

7.3.6 Swivel Bracket (A-BR-S)	66
7.3.7 Junction Box (A-TV-JB)	67
7.3.8 Protective Windows (A-TV-PW)	68
8 MAINTENANCE	69
8.1 Fail-Safe Operation	69
8.2 Troubleshooting	69
8.3 Cleaning the Lens	70
9 APPENDIX	71
9.1 Field of View Calculator	71
9.2 Avoidance of Condensation	72
9.3 Determination of Emissivity	73
9.4 Typical Emissivity Values	73

List of Tables

Table	Page
Table 7-1: Available Ethernet PoE Cables.....	39
Table 7-2: Available Power Supply Cables.....	40
Table 8-3: Troubleshooting	69
Table 9-4: Minimum device temperatures [°C/°F].....	72

List of Figures

Figure	Page
Figure 1-1: Front and Rear View of ThermoView Series Infrared Cameras	14
Figure 1-2: Available Models	15
Figure 1-3: System Architecture for Multiple Cameras and I/O Modules	16
Figure 2-1: Dimensions of ThermoView TV40.....	20
Figure 5-1: Field of View for the Camera.....	23
Figure 5-2: Principal Cabling of Ethernet and Power Supply	24
Figure 5-3: Connecting the Ethernet M12 Cable to the Camera	25
Figure 6-1: LED Status Indicator.....	28
Figure 6-2: Web Server Application	30
Figure 6-3: Dialog Box for Uploading new Firmware.....	31
Figure 6-4: Dialog Box for the Network Configuration	31
Figure 7-1: Wide Lens.....	34
Figure 7-2: Tele Lens 2x	35
Figure 7-3: Tele Lens 4x	36
Figure 7-4: Macro Lens	37
Figure 7-5: Exemplary Ethernet PoE LT Cable	39
Figure 7-6: Pin Assignment (Front View).....	39
Figure 7-7: Power Supply Cable	40
Figure 7-8: Pinout.....	40
Figure 7-9: Ethernet Cable.....	41
Figure 7-10: Ethernet Cable Short.....	41
Figure 7-11: PoE Injector for Office Environments	43
Figure 7-12: Industrial Power Supply	45
Figure 7-13: Mounting Base.....	50
Figure 7-14: Air Purge Collar	51
Figure 7-15: Water Cooling Enclosure.....	53
Figure 7-16: Protective Enclosure	55
Figure 7-17: Dimensions	56
Figure 7-18: Outdoor Enclosure.....	61
Figure 7-19: Dimensions	62
Figure 7-20: Swivel Bracket	66
Figure 7-21: Junction Box	67
Figure 7-22: Protective Window	68
Figure 9-1: Field of View Calculator for the Camera	71

Compliance Statement



The device complies with the requirements of the European Directives:

EC – Directive 2014/30/EU – EMC

EC – Directive 2011/65/EU – RoHS II

EN 61326-1: 2013

Electrical measurement, control and laboratory devices -
Electromagnetic susceptibility (EMC)

EN 50581: 2012

Technical documentation for the evaluation of electrical products with respect to
restriction of hazardous substances (RoHS)



Electromagnetic Compatibility Applies to use in Korea only. Class A Equipment
(Industrial Broadcasting & Communication Equipment)

This product meets requirements for industrial (Class A) electromagnetic wave
equipment and the seller or user should take notice of it. This equipment is intended
for use in business environments and is not to be used in homes.

Safety Information

This document contains important information, which should be kept at all times with the instrument during its operational life. Other users of this instrument should be given these instructions with the instrument. Eventual updates to this information must be added to the original document. The instrument can only be operated by trained personnel in accordance with these instructions and local safety regulations.

Acceptable Operation

This instrument is intended only for the measurement of temperature. The instrument is appropriate for continuous use. The instrument operates reliably in demanding conditions, such as in high environmental temperatures, as long as the documented technical specifications for all instrument components are adhered to. Compliance with the operating instructions is necessary to ensure the expected results.











Unacceptable Operation

The instrument should not be used for medical diagnosis.

Replacement Parts and Accessories

Use only original parts and accessories approved by the manufacturer. The use of other products can compromise the operation safety and functionality of the instrument.



Safety Symbol	Description
	Read all safety information before in the handbook
	Hazardous voltage. Risk of electrical shock.
	Warning. Risk of danger. Important information. See manual.
	Earth (ground) terminal
	Protective conductor terminal
	Switch or relay contact
	DC power supply
	Conforms to European Union directive.
	Disposal of old instruments should be handled according to professional and environmental regulations as electronic waste.
	International Ingress Protection Marking
	China RoHS



To prevent possible electrical shock, fire, or personal injury follow these guidelines:

- Read all safety information before you use the product.
- Use the product only as specified, or the protection supplied by the product can be compromised.
- Do not use the product around explosive gases, vapor, or in damp or wet environments.
- Carefully read all instructions.
- Do not use and disable the product if it is damaged.
- Do not use the product if it operates incorrectly.
- Do not apply more than the rated voltage between the terminals or each terminal and earth ground.
- Incorrect wiring can damage the sensor and void the warranty. Before applying power, make sure all connections are correct and secure!
- To prevent possible electrical shock, fire, or personal injury make sure that the sensor is grounded before use.
- Have an approved technician repair the product.
- The metallic enclosure of the sensor is not necessarily earthed by installation. At least one of the following safety measures must be met to minimize the danger of electrostatic charges:
 - Earth grounding of the cable shield
 - Installing the unit's metallic enclosure on an earth grounded mounting bracket or on any other grounded bases
 - Protect the operator from electrostatic discharge

Contacts

Fluke Process Instruments

America

Everett, WA USA

Tel: +1 800 227 8074 (USA and Canada, only)

+1 425 446 6300

solutions@flukeprocessinstruments.com

EMEA

Berlin, Germany

Tel: +49 30 478 0080

info@flukeprocessinstruments.de

China

Beijing, China

Tel: +86 10 6438 4691

info@flukeprocessinstruments.cn

Technical Support

USA & Canada +65 67995578

Europe +49 30478008444

Latin America +1 831 458 3900

Australia & New Zealand +1 831 458 3900

Asia

Singapore +65 67995578

Japan +81 3 6714 3114

India +65 67995578

China +86 1064384691

techsupport@flukeprocessinstruments.com

www.flukeprocessinstruments.com

1 Description

The ThermoView Series infrared cameras are rugged thermal imagers designed for industrial process control applications in demanding industrial environments. An IP67 rating for the housing is provided if the camera operates with the standard lens and has no external add-on lens attached. All ThermoView infrared cameras are non-contact, highly sensitive infrared thermal imagers with software controlled variable focus capability. In addition, a visible light camera is integrated in the front housing to support the sighting functionality.

The infrared radiation, emitted from measured objects, is detected and converted into an electrical signal by a two-dimensional uncooled focal plane array detector. After this, the amplified analog temperature signal is converted into a digital signal, which can be displayed and analyzed as a colored thermal image using a PC software.

The ThermoView infrared cameras are equipped with the interface standard GigE Vision for high-performance industrial cameras. It supports Power over Ethernet (PoE) which combines a high-speed data transmission with the power supply of the camera even over longer distances.

Figure 1-1: Front and Rear View of ThermoView Series Infrared Cameras

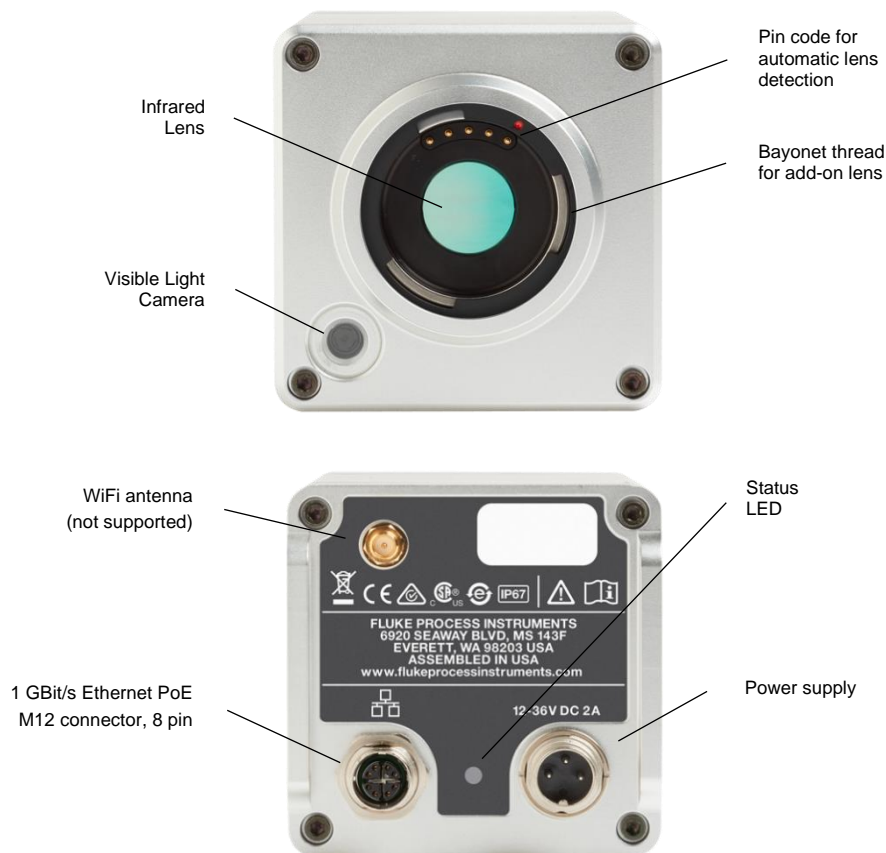

1.1 Available Models

The following ThermoView TV40 model variants are available.

Figure 1-2: Available Models

Model	Temp Range	Infrared Resolution	Lens Type	Field of View Horizontal x Vertical	Focus
TV43	-10 to 1200°C (14 to 2192°F)	320 x 240	Standard Lens	34° x 25.5°	Software controlled
			0.75 x Wide	45° x 34°	Software controlled
			2 x Tele	17° x 12.7°	Software controlled
			4 x Tele	8.5° x 6.3°	Software controlled
			Macro-Lens	7.8 x 4.1 mm (0.31 x 0.16 in)	fixed at 11 mm (0.42 in)
TV46	-10 to 1200°C (14 to 2192°F)	640 x 480	Standard Lens	34° x 25.5°	Software controlled
			0.75 x Wide	45° x 34°	Software controlled
			2 x Tele	17° x 12.7°	Software controlled
			4 x Tele	8.5° x 6.3°	Software controlled
			Macro-Lens	11 x 8.2 mm (0.43 x 0.32 in)	fixed at 11 mm (0.42 in)

TV4	X	X	-	XX	-	X
Series	Model	Temp Range		Software		Frame Rate
	3	L		TL		0
	320 x 240 pixels	-10 to 1200°C (14 to 2192°F)		ThermoView Lite Software		60 Hz
	6			TV		1
	640 x 480 pixels			ThermoView Software		9 Hz

Example: TV43L-TV-0

1.2 System Architecture

Figure 1-3: System Architecture for Multiple Cameras and I/O Modules

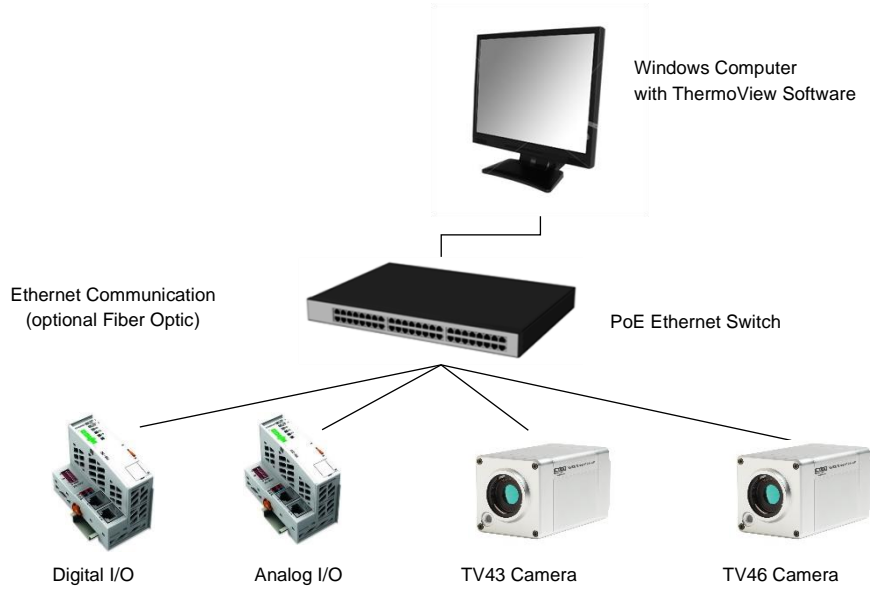

2 Technical Data

2.1 Measurement Specification

Temperature Range	-10°C to 1200°C (14°F to 2192°F) indication starting at -20°C (-4°F)
Spectral Response	8 to 14 μm
Detector, infrared	uncooled focal plane array (micro bolometer)
Resolution (infrared)	
TV43	320 x 240 pixels (76,800 pixels), 24 μm pitch
TV46	640 x 480 pixels (307,200 pixels), 12 μm pitch
Frame Rate (infrared)	
TV43/TV46 model -0	max. 60 Hz (frames per second)
TV43/TV46 model -1	max. 9 Hz (frames per second)
	The infrared frame rate can be changed in 1 Hz steps via the TV40 software.
Resolution (visible)	
TV43/TV46	600 x 450 pixels
Frame Rate (visible)	
TV43/TV46	15 Hz (frames per second)
Data Rate via Ethernet ¹	
TV43	11.7 Mbit/s @ 9 Hz 78 Mbit/s @ 60 Hz data rate = 1.3 Mbit · frame rate (infrared)
TV46	45 Mbit/s @ 9 Hz 300 Mbit/s @ 60 Hz data rate = 5 Mbit · frame rate (infrared)
Thermal Time Constant	12 ms (90%)
Accuracy ²	± 2°C or ± 2% of reading (whichever is greater)
Thermal Sensitivity ³ (NETD)	
TV43	30 mK
TV46	50 mK
Emissivity Correction	0.10 to 1.00

¹ avoid using more than 60% of quoted bandwidth for the given network architecture

² at ambient temperature 25°C (73°F), emissivity = 1.0 and calibration geometry

³ at 30°C (86°F) measuring temperature

2.2 Optical Specifications

The following optical specification is based on the theoretical calculated spot size derived on the pitch of the camera detector array and the lens focal length. Typically, for accurate temperature measurements, the target area needs to be larger than that determined by the calculated theoretical spot sizes, which corresponds to 3 x 3 pixels.

For more technical information on the add-on lenses, see section 7.1 [Add-on Lenses](#), page 33.

2.2.1 Standard Lens

Field of View (FOV)	34° x 25.5° (horizontal x vertical)
Focus Range (infrared)	152 mm to ∞ (0.5 ft to ∞)
Focus, fixed (visible)	600 mm (1.96 ft)

TV43

Instantaneous Field of View (IFOV)	1.9 mrad (1 pixel)
Measurement Field of View (MFOV)	5.6 mrad (3 x 3 pixel)

TV46

Instantaneous Field of View (IFOV)	0.9 mrad (1 pixel)
Measurement Field of View (MFOV)	2.8 mrad (3 x 3 pixel)

Table 2-1: Spot Sizes for Standard Lens

Measuring distance	Thermal image (H x V)	Model	Minimum detectable spot size (1 pixel)	Minimum measurement area (3 x 3 pixel)
0.3 m (1 ft)	0.183 x 0.136 m (0.6 x 0.5 ft)	TV43	0.6 mm (22 mil)	1.7 mm (67 mil)
		TV46	0.3 mm (11 mil)	0.8 mm (33 mil)
0.5 m (1.6 ft)	0.306 x 0.226 m (1 x 0.7 ft)	TV43	0.9 mm (36 mil)	2.8 mm (107 mil)
		TV46	0.5 mm (18 mil)	1.4 mm (53 mil)
1.0 m (3.3 ft)	0.611 x 0.453 m (2 x 1.5 ft)	TV43	1.9 mm (73 mil)	5.6 mm (220 mil)
		TV46	0.9 mm (36 mil)	2.8 mm (110 mil)
5.0 m (16 ft)	3.06 x 2.26 m (9.8 x 7.2 ft)	TV43	9.3 mm (356 mil)	27.8 mm (1068 mil)
		TV46	4.6 mm (178 mil)	13.9 mm (534 mil)
10 m (33 ft)	6.11 x 4.53 m (20.2 x 14.9 ft)	TV43	18.5 mm (734 mil)	55.6 mm (2203 mil)
		TV46	9.3 mm (367 mil)	27.8 mm (1101 mil)

2.3 Electrical Specifications

Digital Interface	GigE Vision (full duplex, 1000 Mbit, TCP/IP, UDP, http-server)
Power Supply	12 – 26 VDC, ± 5% Power over Ethernet (IEEE 802.3at), max 25.4 W
Power Consumption	16 W (max)
LED	lights green at power supply ON

2.4 PC Specifications

1x TV46 camera	Processor: x64 architecture two-core with 3 GHz per core or four-core with 2 GHz per core RAM: 6 GB Hard disk: 20 GB free space, 7200 RPM HDD or an SSD Display: 1920x1080 resolution (minimum - 1280x768) Gigabit Ethernet LAN adapter
2x TV46 cameras	Processor: x64 architecture, four-core with 3 GHz per core or similar RAM: 8 GB Hard disk: 20 GB free space, 7200 RPM HDD or an SSD Display: 1920x1080 resolution (minimum - 1280x768) Gigabit Ethernet LAN adapter

2.5 Environmental Specifications

Ingress Protection	IP67 (IEC 60529) IP54 in combination with an add-on lens
Ambient operating temp.	-10°C to 50°C (14°F to 122°F)
Internal operating temp.	max. 82°C (180°F)
Ambient storage temp.	-20°C to 70°C (-4°F to 158°F)
Humidity	10% to 95%, non-condensing
Shock resistance	IEC60068-2-27: 50 g, 6 ms, 3 axes
Vibration resistance	IEC60068-2-26: 3 g, 11 – 200 Hz, 3 axes
Warm up Period	5 min
Material	Aluminum, bright dipped, anodized, clear coated
Weight	approx. 1 kg (2.2 lb)

2.6 Dimensions

Figure 2-1: Dimensions of ThermoView TV40

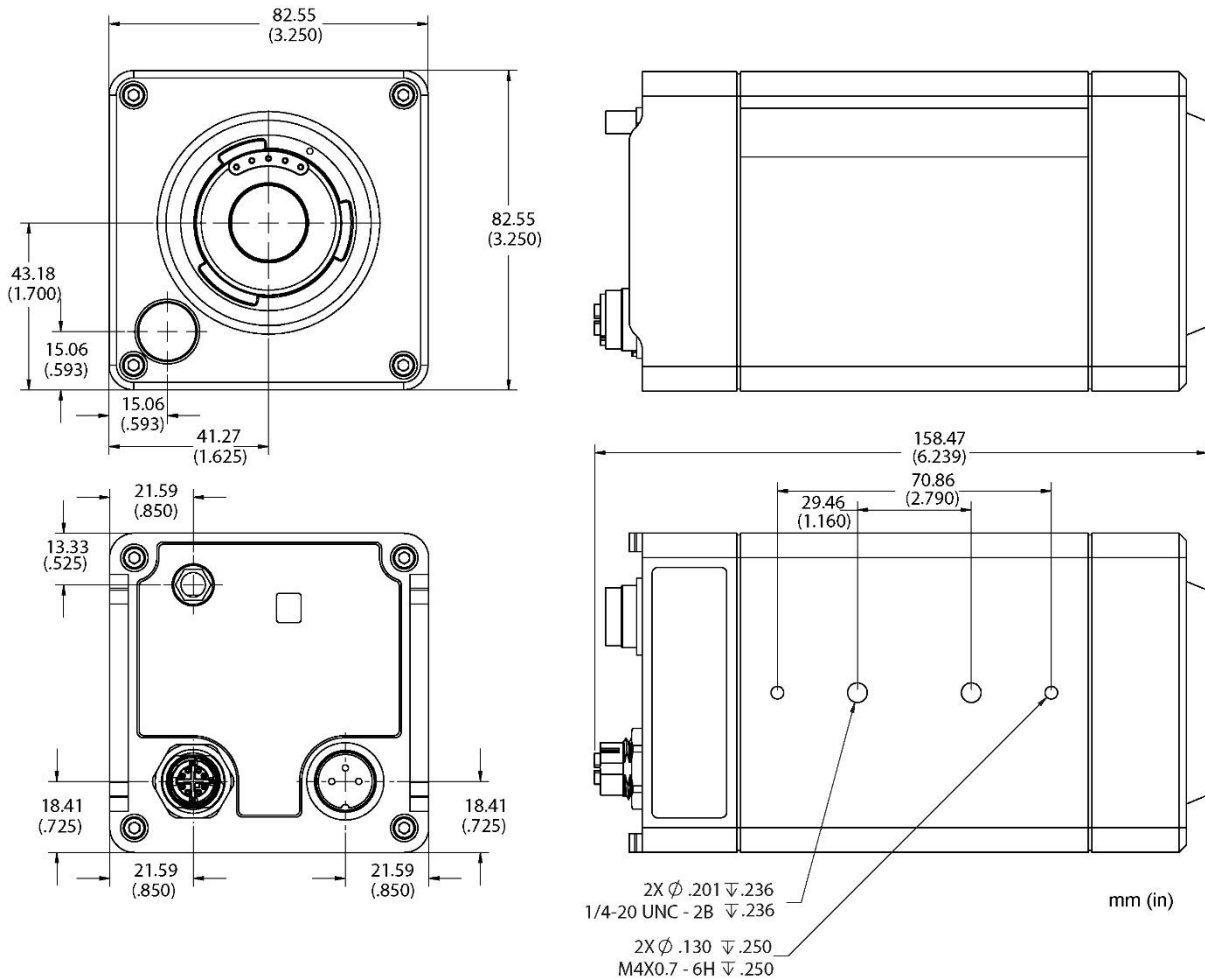

2.7 Scope of Delivery

The scope of standard delivery includes the following:

- ThermoView camera
- User Manual and Quickstart stored in the camera memory
- Metal sealing connector caps (for GigE and power connectors)
- Printed version of Safety Data Sheet & Quickstart

3 Basics

3.1 Measurement of Infrared Temperature

All surfaces emit infrared radiation. The intensity of this infrared radiation changes according to the temperature of the object. Depending on the material and surface properties, the emitted radiation lies in a wavelength spectrum of approximately 1 to 20 μm . The intensity of the infrared radiation (heat radiation) is dependent on the material. For many substances, this material-dependent constant is known. This constant is referred to as the emissivity value.

Infrared cameras are optical-electronic sensors. These sensors are sensitive to the emitted radiation. Infrared cameras consist of a lens, spectral filter, sensor array, and an electronic signal processing unit. The task of the spectral filter is to select the wavelength spectrum of interest. The sensor converts the infrared radiation into an electrical signal. The connected electronics processes this signal for further analysis. The intensity of the emitted infrared radiation is thereby used to determine the temperature of the target. Since the intensity of the infrared radiation is dependent on the material, the appropriate emissivity can be selected on the sensor.

The biggest advantage of the infrared camera is its capability for the contactless determination of target surface temperatures. Consequently, surface temperatures of moving or hard to reach objects can be easily measured.

3.2 Emissivity of Target Object

To determine the emissivity of the target object, see section 9.4 [Typical Emissivity Values](#), page 73. If emissivity is low, measured results could be falsified by interfering infrared radiation from background objects (such as heating systems, flames, fireclay bricks, etc. located close beside or behind the target object). This type of problem can occur when measuring reflective surfaces and very thin materials, such as plastic film and glass.

This measurement error can be reduced to a minimum, if care is taken during installation and the camera is shielded from these reflecting radiation sources.

4 Environment

4.1 Ambient Temperature

Without water cooling, the ThermoView camera is designed for ambient operating temperatures between -15 to 50°C (5 to 122°F). With water cooling equipment, it can be used in environments at higher temperatures.

By forcing water circulation, it is possible to maintain cooled internal housing temperatures. It helps to verify the flow capacity needed and cooling water temperature before proceeding with the installation. It is also necessary to verify the environmental temperature and install the housing at the correct distance from the heating source.

Note that too cold water can cause condensation, which can lead to damage in the device, see section 9.2 [Avoidance of Condensation](#), page 72.

4.2 Atmospheric Quality

If the lens gets dirty, infrared energy will be blocked and the instrument will not measure accurately. It is good practice to always keep the lens clean. The air purge collar accessory helps keep contaminants from building up on the lens, see section 7.3.2 [Air Purge Collar \(A-TV-AP\)](#), page 51. If you use air purging, make sure a filtered air supply with clean, dry air at the correct air pressure is installed before proceeding with the installation.

4.3 Protection

The ThermoView camera without any attached add-on lens complies with the international protection standard IP67. Please note, that the international protection class of IP67 must be downgraded to IP54, if an external add-on lens is attached. Such lenses are not watertight or splash-proof and don't resist harsh environment conditions.

Note that effectiveness against splashing under IP67 is possible only, if terminal caps are in place and all external connectors are connected and comply to IP67 too. To retain the given IP67 protection class, please inspect periodically all seals of the waterproof connectors and end caps.

4.4 Electrical Interference

To minimize electrical or electromagnetic interference or noise, please be aware of the following:

- Mount the instrument as far away as possible from potential sources of electrical interference, such as motorized equipment, which can produce large step load changes.
- Use shielded wire for all input and output connections.
- For additional protection, use conduit for the external connections. Solid conduit is better than flexible conduit in high-noise environments.
- To avoid ground loops, make sure that only ONE POINT is earth grounded, either at the instrument or at the power supply.

Note

When installing the ThermoView camera, check for any high-intensity discharge lamps or heaters that may be in the field of view (either background or reflected on a shiny target)! Reflected heat sources can cause a sensor to give erroneous readings.

5 Installation



Risk of Personal Injury

When this instrument is being used in a critical process that could cause property damage and personal injury, the user should provide a redundant device or system that will initiate a safe process shutdown in the event that this instrument should fail.

5.1 Positioning

Sensor location depends on the application. Before deciding on a location, you need to be aware of the ambient temperature of the location, the atmospheric quality of the location, and the possible electromagnetic interference in that location. If you plan to use air purging, you need to have an air connection available. Wiring and conduit runs must be considered, including computer wiring and connections, if used.

5.2 Distance to Object

The camera provides different lens models to accommodate a wide range of applications. Each individual lens provides different thermal images (Field of View) and minimum detectable pixel sizes (Instantaneous Field of View). The optical diagram below shows the principal graphical representation for measuring distance over the field of view. The manufacturer provides a tool for calculating image sizes, see section 9.1 [Field of View Calculator](#), page 71.

Figure 5-1: Field of View for the Camera

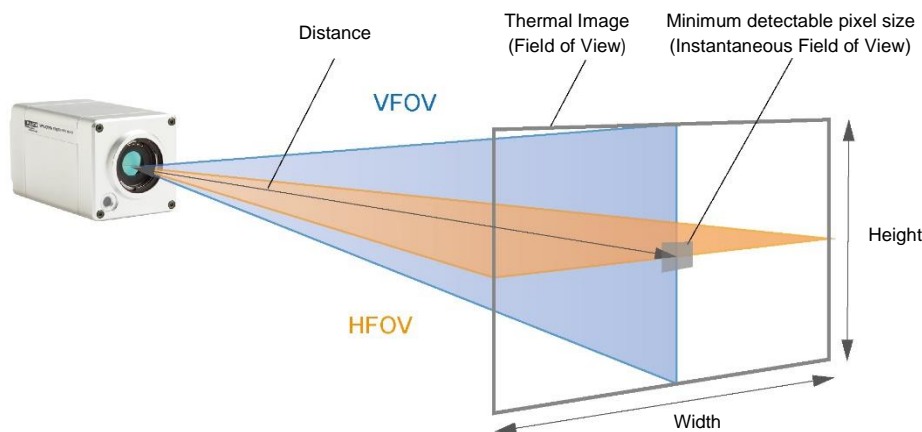

5.3 Focusing

After the camera has been mounted, it is important to make sure that the optimum focus has been established for the given mounting distance. It is important to focus the camera correctly to obtain the sharpest image of the target you wish to view. The motorized focus of the ThermoView camera can be set via the PC software or the built-in web server application.

If the installation distance changes later, it must be ensured that the focus distance is adjusted accordingly.

5.4 Mounting

The camera installation requires the most planning effort. The camera needs to be accurately mounted in relationship to the target. Adjustments to align the camera with the target may have to be designed into the camera

mounting to provide the required alignment accuracy. Avoiding or removing physical mounting limitations and obstructions in the camera's optical path, may also be required.

5.5 Network

The number of cameras in a network is only limited by the PC performance (required frames per second fps). This means the need to consider the speed capability of the network card for transmitting the data and the performance of the CPU for processing and displaying all data. For example, it would be possible to network 32 cameras or maybe more cameras at 1 fps.

5.6 Cabling

Figure 5-2: Principal Cabling of Ethernet and Power Supply

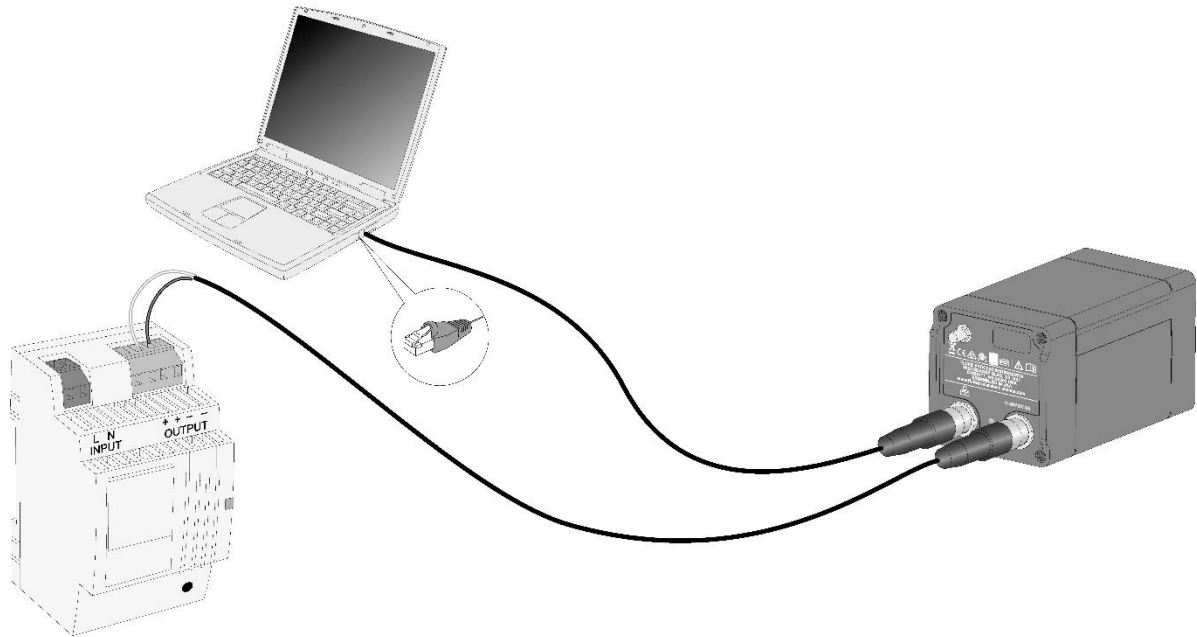

Note

Before connecting and disconnecting any connector, make sure that the device is unpowered!

5.6.1 Ethernet M12 Cable

To connect the Ethernet M12 cable, follow the steps below:

- Remove the rear metal sealed connector cap for the M12 connector at the rear side of the ThermoView camera body
- Attach the male M12 cable plug (2) straight into the female terminal (1) by turning the outer mounting thread (3) in clockwise direction
- Attach the RJ45 connector at the other end of the cable to the related device, like Ethernet switch, computer, fiber optic converter or PLC.

Figure 5-3: Connecting the Ethernet M12 Cable to the Camera

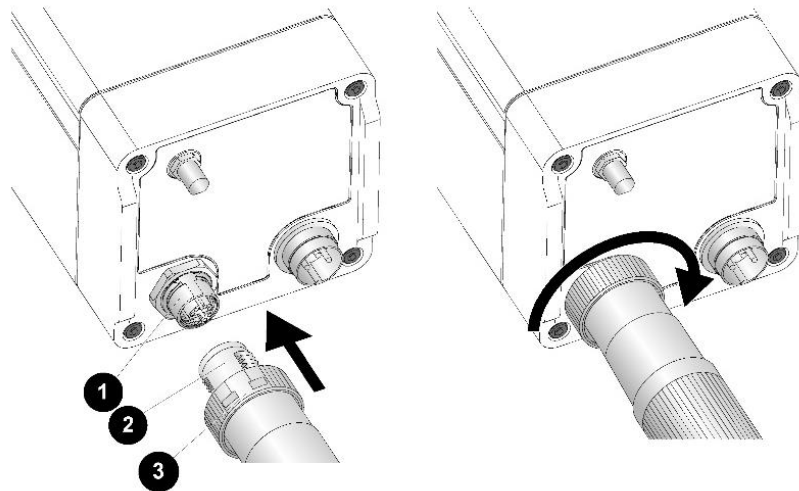

Ethernet cables offered by the manufacturer can be found as electrical accessories, see section 7.2.1 [Ethernet PoE Cable \(A-CB-xx-M12-W08-xx\)](#), page 39.

5.6.2 Power Supply Cable

To connect the power supply cable, follow the steps below:

- Connect the power connector to the camera
- Tighten the outer nut of the female connector
- Supply the open pig tail ends with power (12 – 26 VDC). Take care about the right polarity and connect the **brown** wire to Ground (-) and the **white** wire to +VDC.
- Please leave socket 2 (black wire) at the counter end unwired.

Note

Be very careful in wiring the pig tailed end of the power cable – making sure that the conductor colors on the cable match the correct terminals on the power supply!

Note

The cable shield must be connected to earth ground!

Note

The external power supply should be in the range of 12 to 26 VDC and must not exceed 26 VDC!

Power supply cables offered by the manufacturer can be found as electrical accessories, see section 7.2.2 [Power Supply Cable \(A-CB-xx-PS-xx\)](#), page 40.

A power supply offered by the manufacturer can be found as electrical accessories, see section 7.2.7 [PoE Injector Industrial \(A-TV-POE2\)](#), page 44.

6 Operation

6.1 GigE Vision Communication

The GigE Vision communication is based upon the very fast Gigabit Ethernet (GigE) link, which allows data rates of up to 125 MB/s over cable runs up to 100 m (328 ft.). For digital cameras, especially in the professional image processing domain, is GigE the first-class interface. Even complex installations with multiple cameras are easy feasible and allow a wide support for many devices.

In general, a GigE compliant camera can be powered over the GigE interface (PoE). An additional power supply isn't needed, if a specific PoE injector or PoE switch is used to power the camera via the data cable.

Besides the clear defined physical GigE interface, the GigE Vision standard enhancement exists, to define specific data protocols, data frames, register sets and communication rules. The clear and logical implementation of the GigE Vision standard eases the integration into all image processing software programs via specified software libraries. Such proceeding allows an easy and cost-effective way to exchange a GigE Vision compatible camera by another GigE Vision compliant one, without changing the software application.

The advantages of the GigE interface are:

- High data rates of up to 125 MB/s
- Reusability of existing Ethernet structure
- Cable length up to 100 m (328 ft.)
- Easy integration into image processing software by using of libraries
- High degree of standardization by GigE and GigE Vision standards
- PoE-functionality: power the camera over the Ethernet data cable

6.2 LED Status Indicator

The ThermoView camera has a built-in multi-color LED in the rear panel, which indicates the current health and alarm status.

Figure 6-1: LED Status Indicator



The LED patterns are:

1. Blinking yellow – Booting
2. Solid yellow – Loading operating system
3. Solid green – No errors, IP address obtained and Ethernet cable connected
4. Blinking red – Various errors (can't talk to engine)
5. Blinking green – Flash memory being updated
6. Solid blue – Shutter closed
7. Solid red – Over ambient temperature

Please note that the camera displays these patterns in a priority order, higher numbered events mask lower numbered events. So, for example, the camera is connected to Ethernet (solid green) but have an over-temperature condition. In that case, the LED displays a solid red until the over-temp condition is cleared, then the LED would display solid green.

6.3 Shutter

The camera is equipped with an internal lens shutter. The shutter closes automatically required for a reference recalibration to improve camera performance. It is not a substitute for a factory blackbody calibration. With the shutter closed, no temperature measurements are taking place.

6.4 Web Server Application

The ThermoView camera is equipped with an onboard web-server. Several information is available and will be displayed using a standard web browser. Furthermore, several settings can be initiated and transferred to the imager. It is possible to display or set the device IP address, to modify the focus of the infrared camera or to upload a new firmware. Of course, there are two screen domains for displaying the infrared camera image on the upper screen domain and the visible light camera image on the lower screen domain.

6.4.1 Establishing Communication

For accessing the camera web interface, a standard web browser can be used. For that, you need to know current IP address of the camera.

In case that the camera's IP address is unknown it can be obtained by following the steps below:

- Start the ThermoView software and establish the connection to the camera. Note the current IP address of the camera. The ThermoView software is available for download from the web site of the manufacturer.
- Quit the ThermoView software and open the web browser.
- Type the noted IP address in the address line of the browser.
- A screen similar to the one below indicates a successful established communication.

Figure 6-2: Web Server Application

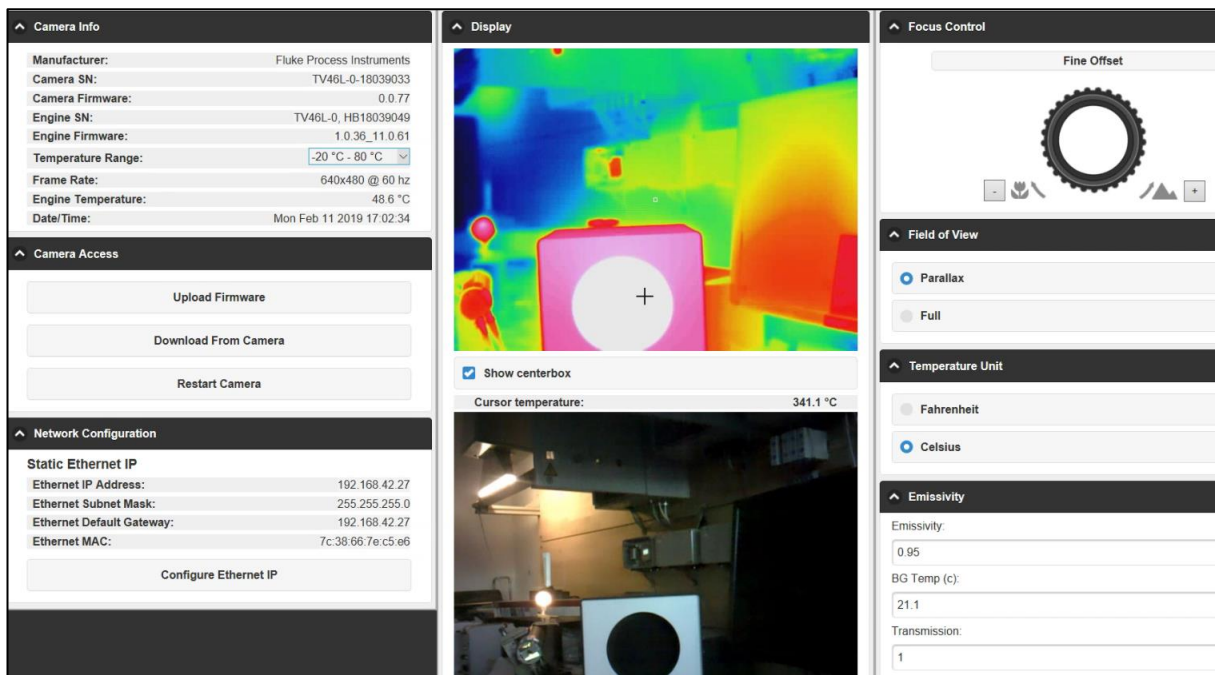

6.4.2 Camera Info

The <Camera Info> menu box displays several information regarding important camera data such as manufacturer, serial number, firmware revision number, current temperature range, pixel resolution, frame rate, and internal case temperature. The <Temperature Range> menu is the only user changeable parameter allowing to switch between <temperature sub range>, <temperature full range>, and <auto>. In the <auto> mode, the camera automatically switches to the best fitting range depending on the measured minimum and maximum temperatures.

6.4.3 Camera Access

The <Camera Access> menu box provides three clickable buttons which behave as following described.

<Upload Firmware> – opens a dialog box which allows to browse for a new firmware file. Contact the TechSupport team for getting latest firmware file available.

Figure 6-3: Dialog Box for Uploading new Firmware

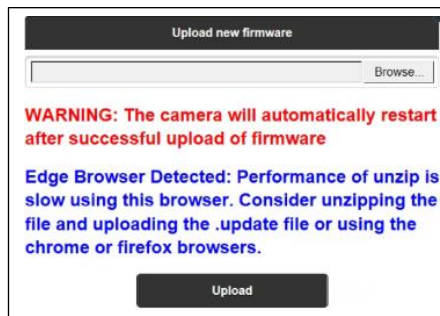

<Download from Camera> – opens a file explorer which allows you to download important camera related files such as the installation file for the ThermoView Software and for the ThermoView Software light as well as the firmware file.

<Restart Camera> – forces the camera to reboot. Please note, most of the parameters set by the browser are lost after a reboot and must be reset (e.g., emissivity).

6.4.4 Network Configuration

The **<Static Ethernet IP>** menu entry provides information on the current network configuration settings. Clicking on the **<Configure Ethernet IP>** button opens the following dialog box:

Figure 6-4: Dialog Box for the Network Configuration

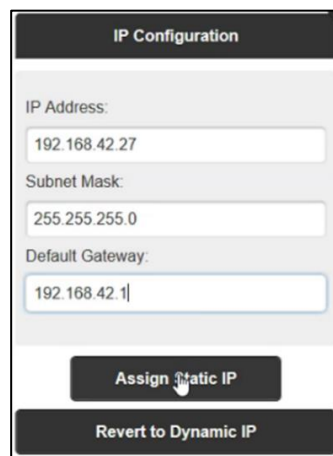

<IP Configuration> – changes the camera network setting in its parameters **<IP address>**, **<Subnet Mask>**, and **<Default Gateway>**.

The camera's **<IP address>** is not free of choice: It must be unique in the network, meaning that no other device in the network (including the PC network adapter) may run at the same IP address.

The **<Subnet Mask>** defines the interpretation of the IP address. A typical setting is 255.255.255.0.

The **<Default Gateway>** must not be the same as the **<IP Address>**.

<Assign Static IP> – clicking on that button forces the camera to quit the **<Dynamic IP>** mode (DHCP) and to activate the **<Static IP>** mode by taking over the parameters given under **<IP configuration>**. A changed network setting requires a reboot of the camera.

<Revert to Dynamic IP> – switches the camera back to the **<Dynamic IP>** mode (DHCP).

6.4.5 Focus Control

The camera is equipped with a motorized focus. The focus setting is applied to the infrared image only. Use the handwheel control to get a sharp image. Clicking on the + and – buttons allows a precise finetuning of the focus control.

6.4.6 Field of View

<Parallax> – this option brings the visual image as well as possible into the area of the infrared image.

<Full> – this option provides the maximum field of view for the visible camera.

6.4.7 Temperature Unit

This menu allows to toggle between Celsius and Fahrenheit.

6.4.8 Emissivity

<Emissivity> – changes the global emissivity. The global emissivity is used to correct the temperature reading of the target. The target may read lower than its true temperature, due to the target emissivity being less than 1.

<BG Temp (c)> – compensates the background temperature (BG) of the surrounding area that might be in the field of view. When the target's emissivity is less than 1, the background temperature can interfere with measurement accuracy. The error is reduced by accurately setting the background temperature. Sometimes it is not possible to completely reduce background induced errors because there could be various background objects of different temperatures reflecting off the target. The best way to minimize these errors is to shield the target as best as possible from stray radiation paths.

<Transmission> – there could be something in the optical path, such as a window that absorbs a percentage of the infrared radiation before it gets to the camera. The transmission value is an adequate correction factor to compensate that effect.

7 Accessories



A full range of accessories for various applications and industrial environments are available. Accessories include items, that may be ordered at any time and added on-site.

7.1 Add-on Lenses

All available add-on lenses are not water tight and have a degraded IP54 rating. There is no need to change the transmission factor in the camera with an added add-on lens.

Please note that attached add-on lenses can restrict the function of the camera. So, the add-on lens could partially obstruct the visible light camera so it is nearly fully covered and can't be used for sighting support. Also, air purge and enclosures cannot be fully utilized, see table below.

Table 7-1: Add-on Lenses and Accessories

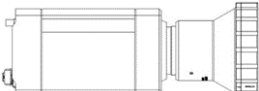
		Air Purge Collar	Water Cooling Enclosure	Protective Enclosure	Outdoor Enclosure	Visual Camera
Standard lens		✓	✓	✓	✓	✓
Wide Lens 0.75x		✗	✗	✓	✓	✓
Tele lens 2x		✗	✗	✗	✓	✗
Tele lens 4x		✗	✗	✗	✗	✗
Macro lens		✗	✗	✗	✗	✗

7.1.1 Wide Lens 0.75x

Field of View (FOV) 45° x 34° (horizontal x vertical)
 Focus Range (infrared) 152 mm to ∞ (0.5 ft to ∞)
 Focus, fixed (visible) 600 mm (1.96 ft)

TV43

Instantaneous Field of View (IFOV) 2.5 mrad (1 pixel)
 Measurement Field of View (MFOV) 7.4 mrad (3 x 3 pixel)

TV46

Instantaneous Field of View (IFOV) 1.2 mrad (1 pixel)
 Measurement Field of View (MFOV) 3.7 mrad (3 x 3 pixel)

Table 7-2: Spot Sizes for Wide Lens 0.75x

Measuring distance	Thermal image (H x V)	Model	Minimum detectable spot size (1 pixel)	Minimum measurement area (3 x 3 pixel)
0.3 m (1 ft)	0.249 x 0.183 m (0.8 x 0.6 ft)	TV43	0.7 mm (29 mil)	2.2 mm (88 mil)
		TV46	0.4 mm (14 mil)	1.1 mm (44 mil)
0.5 m (1.6 ft)	0.414 x 0.306 m (1.3 x 1 ft)	TV43	1.2 mm (47 mil)	3.7 mm (141 mil)
		TV46	0.6 mm (24 mil)	1.8 mm (70 mil)
1.0 m (3.3 ft)	0.828 x 0.611 m (2.7 x 2 ft)	TV43	2.5 mm (97 mil)	7.4 mm (292 mil)
		TV46	1.2 mm (49 mil)	3.7 mm (146 mil)
5.0 m (16 ft)	4.14 x 3.06 m (13.3 x 9.8 ft)	TV43	12.3 mm (471 mil)	36.8 mm (1414 mil)
		TV46	6.1 mm (236 mil)	18.4 mm (707 mil)
10 m (33 ft)	8.28 x 6.11 m (27.3 x 20.2 ft)	TV43	24.5 mm (972 mil)	73.6 mm (2916 mil)
		TV46	12.3 mm (486 mil)	36.8 mm (1458 mil)

Figure 7-1: Wide Lens

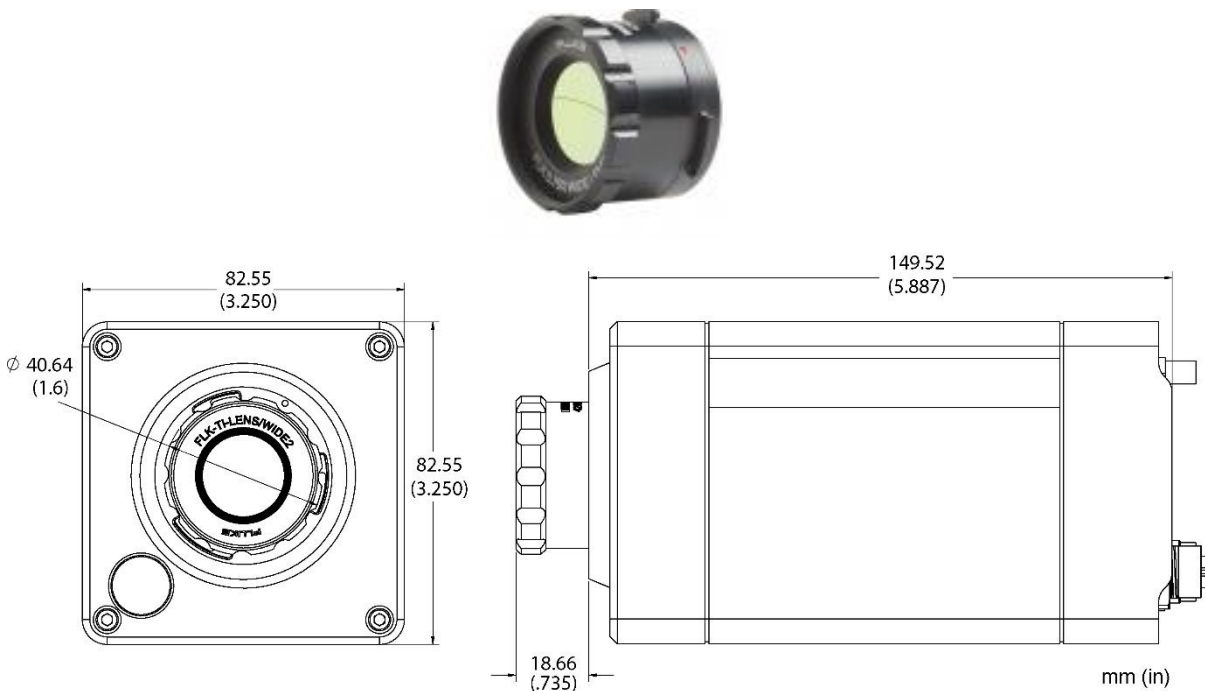

7.1.2 Tele Lens 2x

Field of View (FOV) 17° x 12.7° (horizontal x vertical)
 Focus Range (infrared) 406 mm to ∞ (1.3 ft to ∞)
 Focus, fixed (visible) 600 mm (1.96 ft)

TV43

Instantaneous Field of View (IFOV) 0.9 mrad (1 pixel)
 Measurement Field of View (MFOV) 2.8 mrad (3 x 3 pixel)

TV46

Instantaneous Field of View (IFOV) 0.5 mrad (1 pixel)
 Measurement Field of View (MFOV) 1.4 mrad (3 x 3 pixel)

Table 7-3: Spot Sizes for Tele Lens 2x

Measuring distance	Thermal image (H x V)	Model	Minimum detectable spot size (1 pixel)	Minimum measurement area (3 x 3 pixel)
0.5 m (1.6 ft)	0.149 x 0.111 m (0.5 x 0.4 ft)	TV43	0.5 mm (18 mil)	1.4 mm (53 mil)
		TV46	0.2 mm (9 mil)	0.7 mm (27 mil)
1.0 m (3.3 ft)	0.299 x 0.223 m (1 x 0.7 ft)	TV43	0.9 mm (37 mil)	2.8 mm (110 mil)
		TV46	0.5 mm (18 mil)	1.4 mm (55 mil)
5.0 m (16 ft)	1.49 x 1.11 m (4.8 x 3.6 ft)	TV43	4.6 mm (178 mil)	13.9 mm (534 mil)
		TV46	2.3 mm (89 mil)	7 mm (267 mil)
10 m (33 ft)	2.99 x 2.23 m (9.9 x 7.3 ft)	TV43	9.3 mm (367 mil)	27.8 mm (1102 mil)
		TV46	4.6 mm (184 mil)	13.9 mm (551 mil)

Figure 7-2: Tele Lens 2x



7.1.3 Tele Lens 4x

Field of View (FOV) 8.5° x 6.3° (horizontal x vertical)
 Focus Range (infrared) 2540 mm to ∞ (8.3 ft to ∞)
 Focus, fixed (visible) 600 mm (1.96 ft)

TV43

Instantaneous Field of View (IFOV) 0.5 mrad (1 pixel)
 Measurement Field of View (MFOV) 1.4 mrad (3 x 3 pixel)

TV46

Instantaneous Field of View (IFOV) 0.2 mrad (1 pixel)
 Measurement Field of View (MFOV) 0.7 mrad (3 x 3 pixel)

Table 7-4: Spot Sizes for Tele Lens 4x

Measuring distance	Thermal image (H x V)	Model	Minimum detectable spot size (1 pixel)	Minimum measurement area (3 x 3 pixel)
3.0 m (9.8 ft)	0.446 x 0.330 m (1.5 x 1.1 ft)	TV43	1.4 mm (54 mil)	4.2 mm (164 mil)
		TV46	0.7 mm (27 mil)	2.1 mm (82 mil)
5.0 m (16 ft)	0.74 x 0.55 m (2.4 x 1.8 ft)	TV43	2.3 mm (89 mil)	7 mm (267 mil)
		TV46	1.2 mm (44 mil)	3.5 mm (134 mil)
10 m (33 ft)	1.49 x 1.1 m (4.9 x 3.6 ft)	TV43	4.6 mm (184 mil)	13.9 mm (551 mil)
		TV46	2.3 mm (92 mil)	7 mm (275 mil)

Figure 7-3: Tele Lens 4x

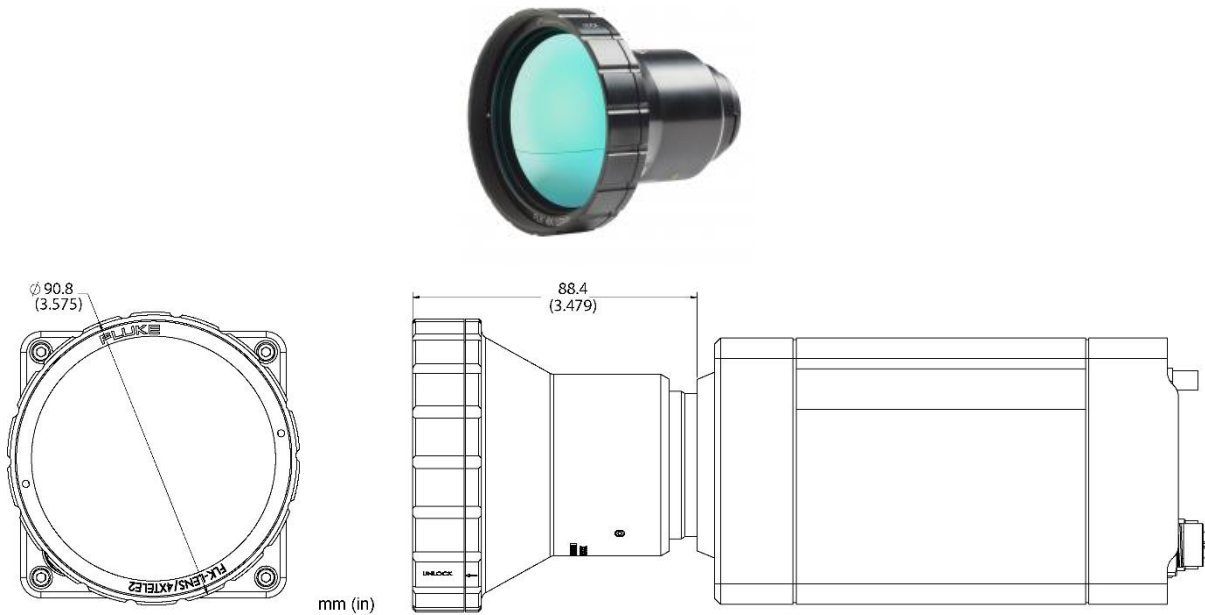

7.1.4 Macro

TV43

Field of View (FOV) 16.7° x 12.5° (horizontal x vertical)

TV46

Field of View (FOV) 23.8° x 17.8° (horizontal x vertical)

TV43/TV46

Focus, fixed (infrared) 10.8 mm (0.42 in)

Table 7-5: Spot Sizes for Macro TV43

Measuring distance	Thermal image (H x V)	Minimum detectable spot size (1 pixel)	Minimum measurement area (3 x 3 pixel)
10.8 mm (0.42 in)	7.8 x 4.1 mm (0.31 x 0.16 in)	17 µm (0.67 mil)	51 µm (2 mil)

Table 7-6: Spot Sizes for Macro TV46

Measuring distance	Thermal image (H x V)	Minimum detectable spot size (1 pixel)	Minimum measurement area (3 x 3 pixel)
10.8 mm (0.42 in)	11 x 8.2 mm (0.43 x 0.32 in)	12 µm (0.47 mil)	36 µm (1.4 mil)

Figure 7-4: Macro Lens



7.2 Electrical Accessories

The following electrical accessories are available:

- Ethernet PoE Cable (A-CB-xx-M12-W08-xx)
- Power Supply Cable (A-CB-xx-PS-xx)
- Ethernet Cable (A-CB-LT-RJ45-25)
- Ethernet Cable Short (A-CB-LT-RJ45-03)
- Fiber Optic Cable (A-CB-FO-xxx)
- PoE Injector (A-TV-POE1)
- PoE Injector Industrial (A-TV-POE2)
- Power Supply DIN Rail (A-PS-DIN-24V)
- Fiber Optic to Ethernet Converter (A-CON-FO-RJ45)
- Ethernet Switch (A-CON-SW)
- I/O Modules

7.2.1 Ethernet PoE Cable (A-CB-xx-M12-W08-xx)

The Ethernet PoE cable comes with an eight-pin male M12 connector, assigned to the cameras rear eight-socket female M12 connector. The corresponding end of the Ethernet PoE cable is equipped with a general RJ45 snap-in connector. The cable is about 7 mm (0.3 in) in outer diameter.

The LT version of the cable withstands ambient temperatures up to 80°C (176°F), the HT version withstands ambient temperatures up to 165°C (329°F).

In case of using PoE (Power over Ethernet) to supply the imager with power, the needed power is injected over the existing data wires.

For information about installation, see section 5.6.1 [Ethernet M12 Cable](#), page 24.

Figure 7-5: Exemplary Ethernet PoE LT Cable

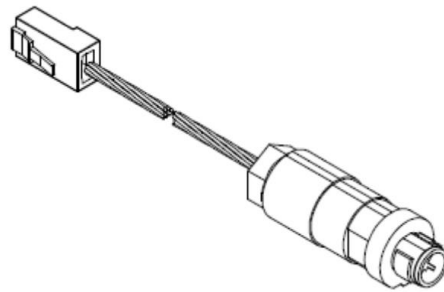

Figure 7-6: Pin Assignment (Front View)

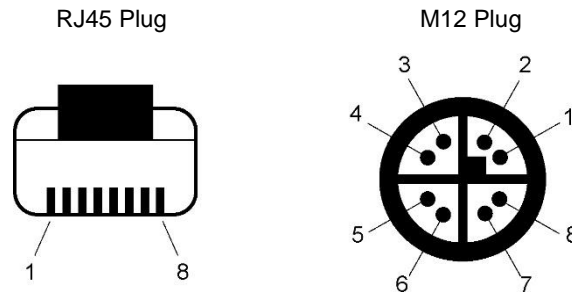

Table 7-1: Available Ethernet PoE Cables

P/N	Length	Ambient Temperature
A-CB-LT-M12-W08-07	7.5 m (25 ft)	80°C (176°F)
A-CB-LT-M12-W08-25	25 m (82 ft)	80°C (176°F)
A-CB-LT-M12-W08-50	50 m (164 ft)	80°C (176°F)
A-CB-HT-M12-W08-07	7.5 m (25 ft)	165°C (329°F)
A-CB-HT-M12-W08-10	10 m (33 ft)	165°C (329°F)

7.2.2 Power Supply Cable (A-CB-xx-PS-xx)

The power supply cable comes with a three-socket female M16 connector, assigned to the cameras rear three pin male M16 connector. The corresponding end of the power supply cable is carried out as a pig tail, to connect to an external power supply device.

The power supply cable is about 5 mm (0.2 in) in outer diameter and is provided in different lengths. The LT version of the cable withstands ambient temperatures up to 80°C (176°F), the HT version withstands ambient temperatures up to 180°C (356°F).

For information about installation, see section 5.6.2 [Power Supply Cable](#), page 26.

Figure 7-7: Power Supply Cable



Figure 7-8: Pinout

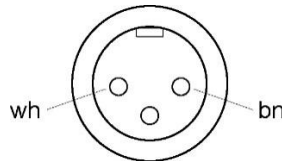

Table 7-2: Available Power Supply Cables

P/N	Length	Ambient Temperature
A-CB-LT-PS-07	7.5 m (25 ft)	80°C (176°F)
A-CB-LT-PS-25	25 m (82 ft)	80°C (176°F)
A-CB-LT-PS-50	50 m (164 ft)	80°C (176°F)
A-CB-HT-PS-08	7.5 m (25 ft)	180°C (356°F)
A-CB-HT-PS-10	10 m (33 ft)	180°C (356°F)

7.2.3 Ethernet Cable (A-CB-LT-RJ45-25)

The Ethernet cable comes with RJ45 connectors on both ends in a length of 25 m (82 ft).

Figure 7-9: Ethernet Cable



7.2.4 Ethernet Cable Short (A-CB-LT-RJ45-03)

The Ethernet cable short comes with RJ45 connectors on both ends in a length of 0.3 m (1 ft).

Figure 7-10: Ethernet Cable Short



7.2.5 Fiber Optic Cable (A-CB-FO-xxx)

Use fiber optic communication for Ethernet cable runs beyond 90 m (295 ft). The cables are available in the following lengths:

- 150 m (492 ft), part number A-CB-FO-150
- 300 m (984 ft), part number A-CB-FO-300

Specification

Connector	SC
Application	outdoor
Armoring	armoring plus PE protective sheath
Cable type	multimode (graded index)
Fiber core	50 µm
Cladding	125 µm

7.2.6 PoE Injector (A-TV-POE1)

The PoE Injector (A-TV-POE1) is intended to use in office environments.

With PoE (Power over Ethernet), the injector transfers both data and electrical power to Ethernet-enabled devices using a standard CAT5 cable. The injector injects up to 30 W for the attached device(s). It operates at an ambient temperature up to 55°C (131°F).

Figure 7-11: PoE Injector for Office Environments



1

Specification:

- Single-port Gigabit PoE Midspan, 802.3at Compliant with 2-event classification
- Backwards compatible with IEEE802.3af
- 30 W output power from ambient -20 to +40°C (-4 to 104°F), 25 W output at +55°C (131°F)
- 1000 Base-T compatible
- Safe & reliable power over existing Ethernet infrastructure
- Automatic detection and protection of non-standard devices
- Plug-and-play installation
- AC Input Voltage 100 to 240 VAC (50 to 60 Hz)
- Indicator: AC power (yellow), Channel power (green)

¹ Copyright Microsemi®

7.2.7 PoE Injector Industrial (A-TV-POE2)

The PoE Injector Industrial (A-TV-POE2) is intended to use in industrial environments.

With PoE (Power over Ethernet), the injector transfers both data and electrical power to Ethernet-enabled devices using a standard CAT5 cable. The injector injects up to 30 W for the attached device(s). It operates in a wide temperature range between up to 75°C (167°F). The injector is DIN-rail or wall mountable.

Communications

Standard	IEEE 802.3, 802.3u, 802.3x, 802.3af/at, 802.3ab
LAN	10/100/1000Base-T (X)
Transmission Distance	max. 100 m (328 ft)
Transmission Speed	up to 1000 Mbps

Interface

Connectors	PoE OUT: RJ45, DATA IN: RJ45 6-pin removable screw terminal
------------	--

Power

Power Consumption	max. 33.36 W @ 24 VDC (Full load PoE)
Power Input	24 to 48 VDC, redundant dual power inputs
Power Output	30 W @ 55 VDC

Environment

Operating Temperature	-40 to 75°C (-40 to 167°F)
Storage Temperature	-40 to 85°C (-40 to 185°F)
Operating Humidity	5 to 95% (non-condensing)
Storage Humidity	0 to 95% (non-condensing)

7.2.8 Power Supply DIN Rail (A-PS-DIN-24V)

The DIN-rail mount industrial power supply delivers isolated dc power and provides short circuit and overload protection.



Risk of Personal Injury

To prevent electrical shocks, the power supply must be used in protected environments (cabinets)!

Technical data:

Protection class	prepared for class II equipment
Environmental protection	IP20
Operating temperature range	-25°C to 55°C (-13°F to 131°F)
AC Input	100 – 240 VAC 44/66 Hz
DC Output	24 VDC / 1.3 A
Cross sections	input/output 0.08 to 2.5 mm ² (AWG 28 to 12)

Figure 7-12: Industrial Power Supply

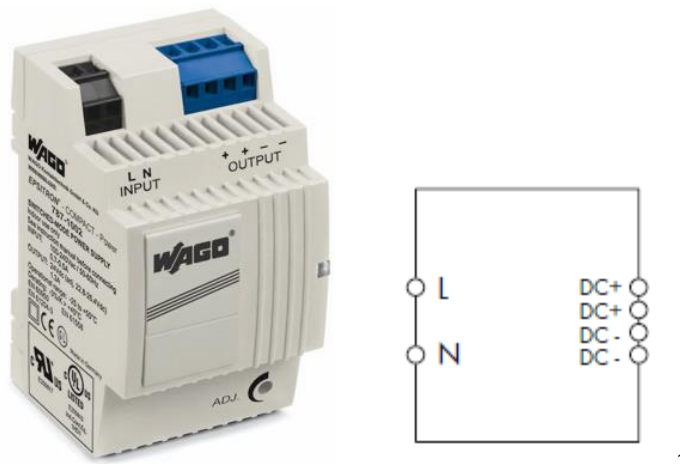

¹ Copyright Wago®

7.2.9 Fiber Optic to Ethernet Converter (A-CON-FO-RJ45)

The Fiber Optic Converter (A-CON-FO-RJ45) is an industrial Ethernet switch with 6 RJ45 GBit Ethernet ports and 2 multi-mode GBit fiber optic ports. The converter is DIN-rail or wall mountable.

Communications

Standard	IEEE 802.3, 802.3u, 802.3ab, 802.3x, IEEE 802.3z
LAN	10/100/1000Base-T (X), 1000Base-SX or 1000Base-LX
Transmission Distance	Ethernet: max. 100 m (328 ft) Multi-mode: up to 550 m (1804 ft)
Transmission Speed	up to 1000 Mbps

Optical Fiber

Multi-mode	wavelength: 850 nm parameters: 50/125 μm , 62.5/125 μm
------------	---

Interface

Connectors	6 x RJ45 ports, 2 x SC type fiber optic 6-pin removable screw terminal (power & relay)
------------	---

Power

Power Consumption	7 W
Power Input	12 to 48 VDC, 24 VAC (18 to 30 VAC), redundant dual inputs

Environment

Operating Temperature	-40 to 75°C (-40 to 167°F)
Storage Temperature	-40 to 85°C (-40 to 185°F)
Operating Humidity	10 to 95% (non-condensing)
Storage Humidity	10 to 95% (non-condensing)

7.2.10 Ethernet Switch (A-CON-SW)

The Ethernet Switch (A-CON-SW) has 4 x 10/100/1000BASE-T Ethernet ports with PoE+ functionality and 2 x SFP sockets. It works within a wide operating temperature range. This switch can provide 30 W output per PoE port. The switch is DIN-rail or wall mountable.

Communications

Standard	IEEE 802.3, 802.3u, 802.3x, 802.3af/at, 802.3ab, 802.3z
LAN	10/100/1000BASE-T 1000BASE-SX/LX/LHX/XD/ZX/EZX
Transmission Distance	Ethernet: max. 100 m (328 ft) SFP: up to 110 km (depends on SFP)
Transmission Speed	Copper: 10/100/1000 Mbps, Auto-Negotiation Gigabit Fiber: Up to 1000 Mbps

Interface

Connectors	4x ports, 10/100/1000T(X), RJ-45 2x ports, SFP: Gigabit Base
------------	---

Power

Power Consumption	5.5 W @ 48 VDC (Ethernet only)
Power Input	48 VDC (44 VDC to 57 VDC), redundant dual inputs
Fault Output	1 Relay Output

Environment

Operating Temperature	-40 to 75°C (-40 to 167°F)
Storage Temperature	-40 to 85°C (-40 to 185°F)
Operating Humidity	5 to 95% (non-condensing)

7.2.11 I/O Modules

The following I/O modules are available for the TV40 imager:

- A-CON-BASICKIT Basic Kit, consists of the following items:
Fieldbus Coupler 750-352
Supply Module 750-602
End Module 750-600
Support software with communication cable
- A-CON-16DI Digital Input Module 750-1406
- A-CON-16DO Digital Output Module 750-1504
- A-CON-2AOC4 Analog Output Module 750-563, preset to 4 – 20 mA
- A-CON-2AOC0 Analog Output Module 750-563, preset to 0 – 20 mA
- A-CON-2R Relay Output Module 750-513
- A-CON-2A-ISO Passive Isolator 857-452
- A-PS-DIN-24V Power Supply 787-1002

I/O accessories need to be configured and installed by the user. The powering of the camera requires the power supply A-PS-DIN-24V unless customer supplies power to camera separately.

For more detailed information, see the manual „I/O Module System for Thermal Imagers“.

7.3 Mechanical Accessories

The following mechanical accessories are available:

- Mounting Base (A-TV-MB)
- Air Purge Collar (A-TV-AP)
- Water Cooling Enclosure (A-TV-AP-WC)
- Protective Enclosure (A-TV-WC)
- Outdoor Enclosure (A-TV-ENC)
- Swivel Bracket (A-BR-S)
- Junction Box (A-TV-JB)
- Protective Windows (A-TV-PW)

7.3.1 Mounting Base (A-TV-MB)

The Mounting Base (A-TV-MB) is to adapt the imager in an easy way to any kind of fixture. For the fixture to tripods or swivel brackets, the mounting base provides 2 inner ¼" – 20 holes.

Figure 7-13: Mounting Base

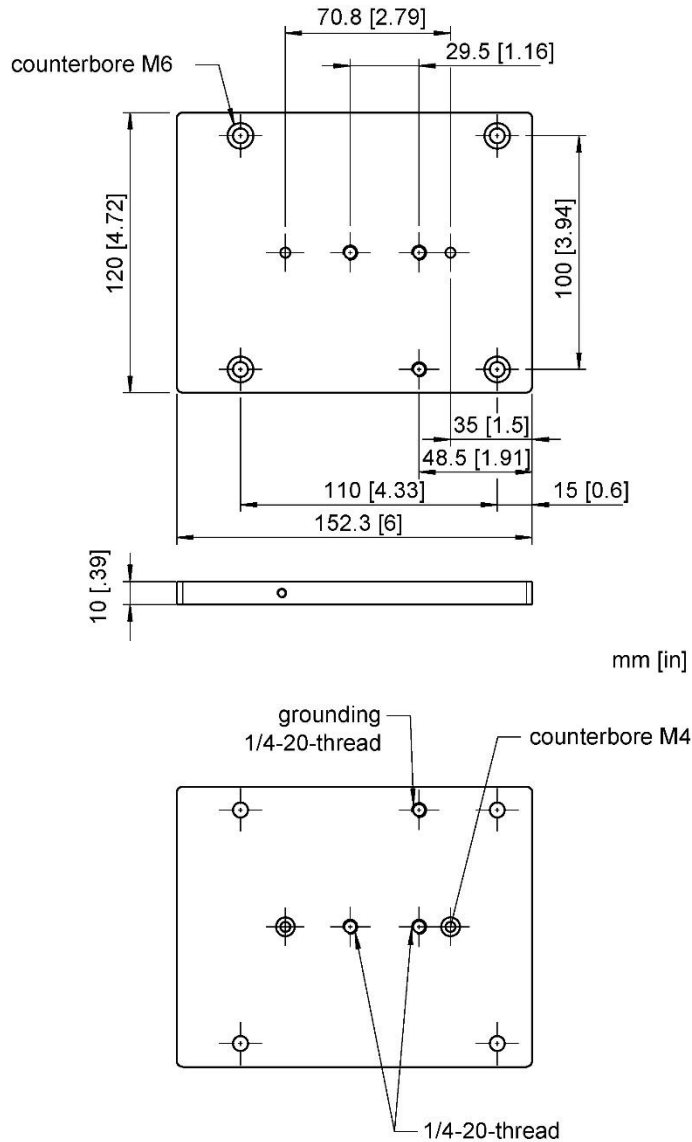

7.3.2 Air Purge Collar (A-TV-AP)

The Air Purge Collar (A-TV-AP) is used to keep dust, moisture, airborne particles, and vapors away from the lens. Air flows into the 1/8" NPT fitting and out the front aperture. Clean filtered (or "instrument") air is recommended to avoid contaminants from settling on the lens. Do not use chilled air below 10°C (50°F).

- Air flow rate: 30 to 60 l / min (8 to 16 gallon / minute)
- Air pressure: max. 5 bar (72.5 psi)

Note

To avoid erroneous readings, ensure that the transmission of 0.94 for the built-in protective window (Germanium) must be set in the thermal imager!

Figure 7-14: Air Purge Collar

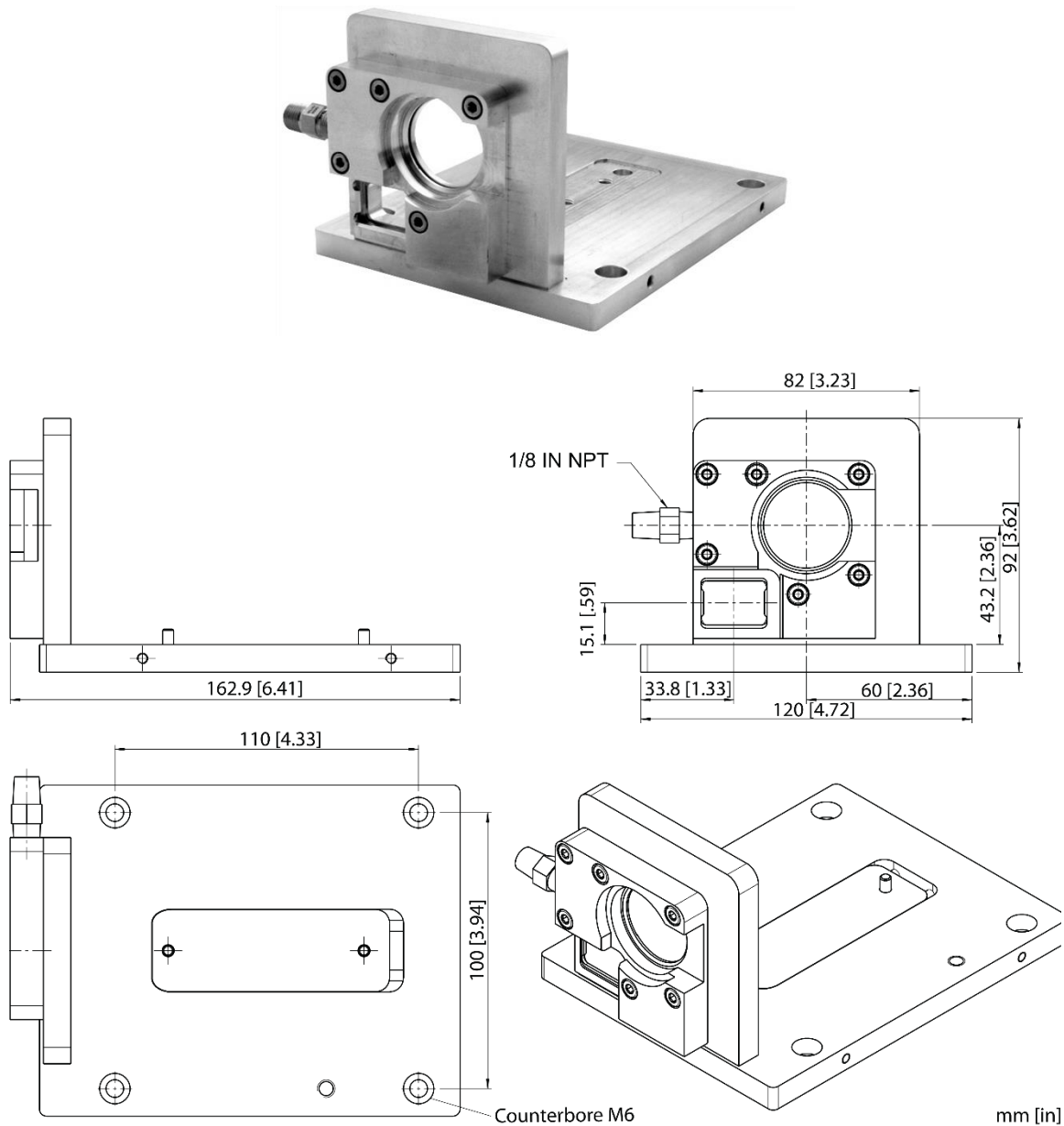

To install the Air Purge Collar, follow the mounting steps as described below.

Use the enclosed screws to attach the mounting carriage to the bottom of the camera body.

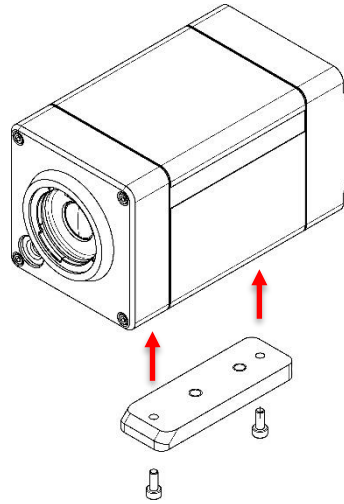

Place the camera body on the base plate of the air purge. In this case, the mounting carriage must be inserted in the appropriate opening of the base plate.

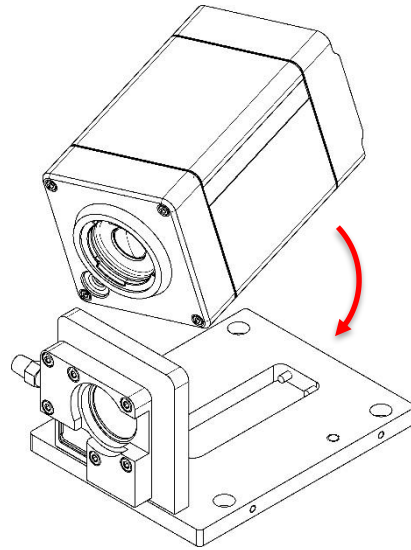

Secure the camera with the screws as shown in the picture.

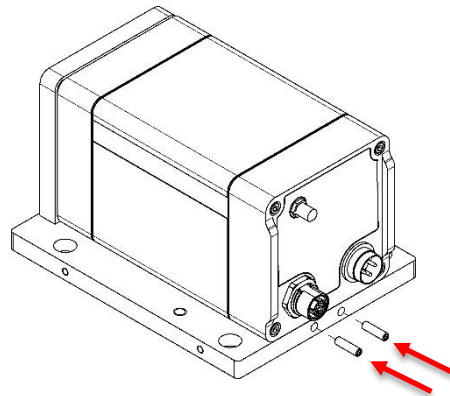

7.3.3 Water Cooling Enclosure (A-TV-AP-WC)

The Water Cooling Enclosure (A-TV-AP-WC) allows the camera to be used in ambient temperatures up to 140°C (284°F) with water cooling. The cooling media should be connected using 3/8" NPT fittings requiring 8.1 mm (0.32 in) inner diameter and 9.525 mm (0.37 in) outer diameter for the tube.

Max. ambient temperature: 140°C (284°F)
 at water inlet temperature of 20°C (68°F)
 and a flow rate of 1.6 l / min (0.4 gallon / minute),
 chilled water below 10°C (50°F) is not recommended

Note

For ambient temperatures exceeding 140°C (284°F), the protective enclosure can be used. This accessory allows operation at ambient temperatures up to 200°C (392°F)

The water cooling enclosure comes with an air purge collar. The air purge should be always used to keep the lens dry. For more information, see section 7.3.2 [Air Purge Collar \(A-TV-AP\)](#), page 51.

Figure 7-15: Water Cooling Enclosure

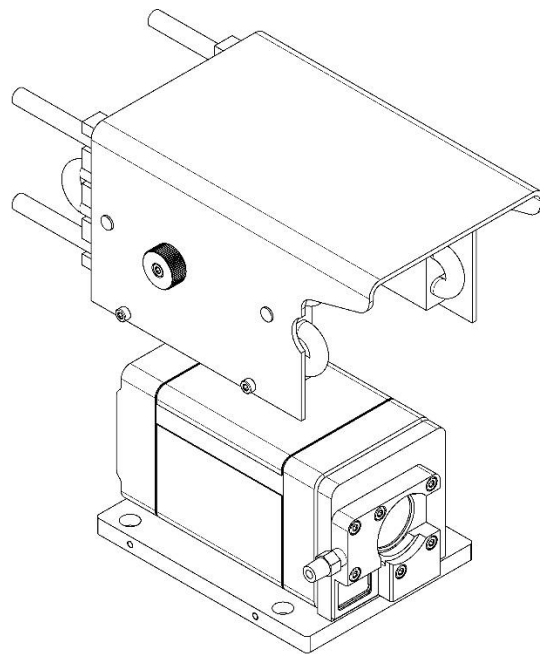

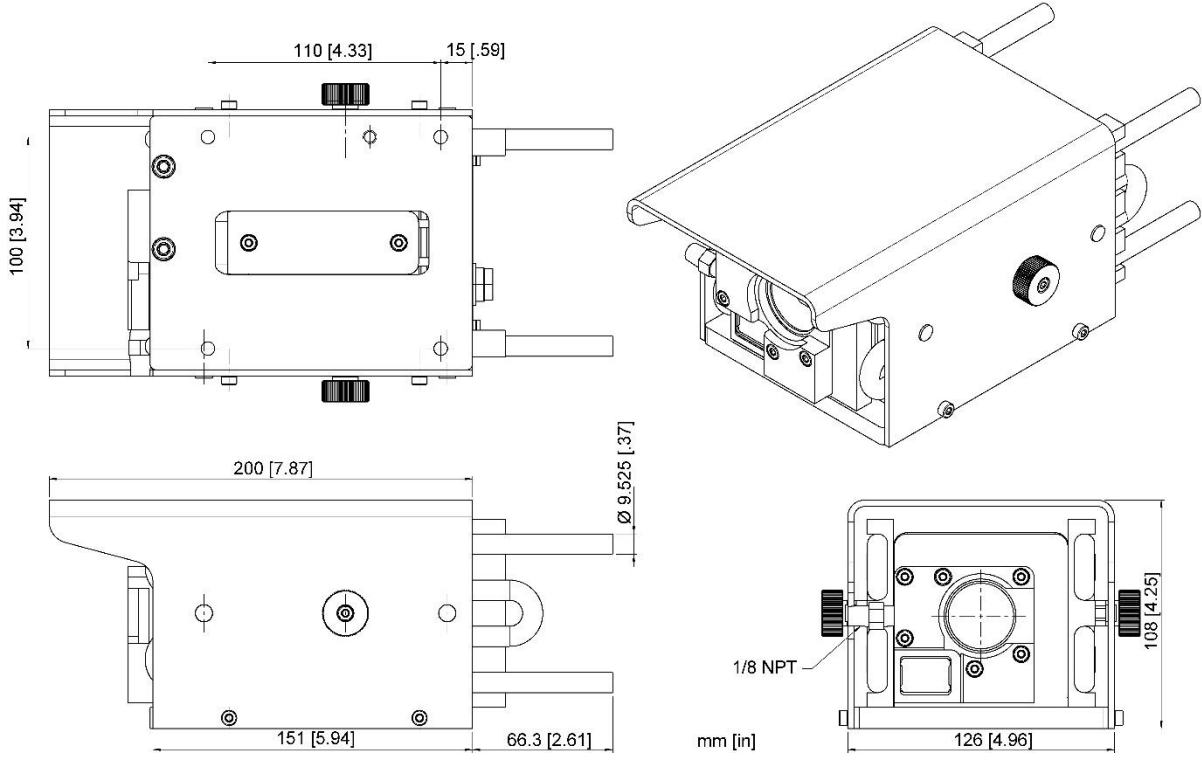

7.3.4 Protective Enclosure (A-TV-WC)

When the camera is installed in dirty and hot environments, the protective enclosure (A-TV-WC) provides water cooling and air purge for protection.

7.3.4.1 Air Barrier

The flange for window cleaning uses ventilation to create an air barrier on the front of the housing to prevent any deposits of dust on the outer surface of the window. For proper use, it is always advisable to filter the compressed air with a dedicated filter that is equipped with a gauge pressure regulator. For proper installation, it is necessary to check the environmental temperature and place the air filter group at the correct distance from the heat source.

Note

For optimal performance of air barrier, it is recommended positioning the enclosure in a horizontal position or decline angle. Positioning the enclosure with the air barrier vertically may affect its performance!

Note

To avoid erroneous readings, ensure that the transmission of 0.96 for the built-in protective window (Zinc Selenide) must be set in the thermal imager!



Risk of Personal Injury

Noise level emissions produced by air barrier may exceed recommend safe exposure levels!

Figure 7-16: Protective Enclosure



7.3.4.2 Specification

Scope of delivery

- Enclosure with cooling jacket and Zinc Selenide window
- 2x cable glands (M25 x 1.5)
- Mounting material

Environment

Rating IP67
 Ambient temperature 200°C (392°F)
 with a flow rate of 6 l / min (1.6 gal / min), water at 20°C (68°F) inlet temperature and 6 bar (87 psi) for front air barrier
 Air pressure 4 to 6 bar (58 to 87 psi) recommended

Mechanical

Construction stainless steel, AISI 316L, polished
 Weight 13 kg (29 lb), without thermal camera
 Cable gland M12x1.5, threaded holes on the rear flange

Figure 7-17: Dimensions

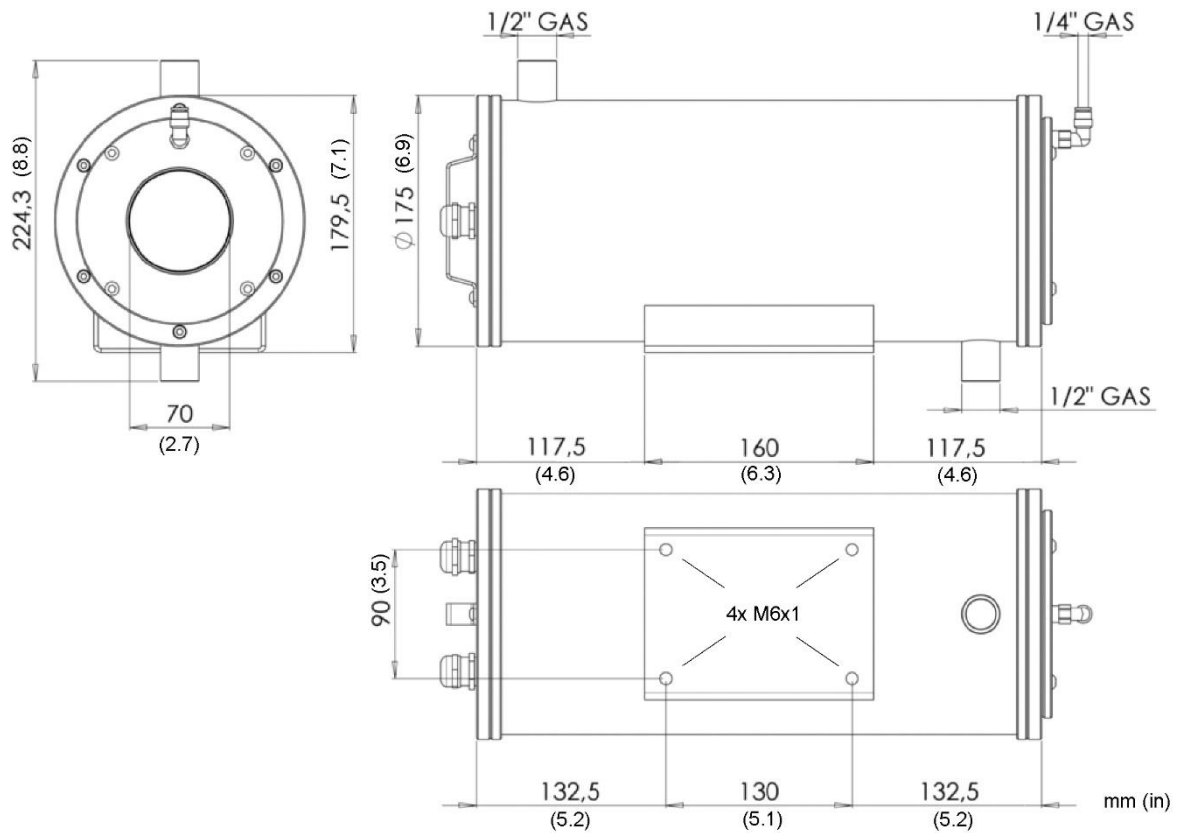

7.3.4.3 Installation

Note

The camera can only be mounted in the protective housing with standard lens or with wide lens. A mounting with tele or macro lens is not possible!

Note

For better handling, an additional handle can optionally be mounted on the housing. See the enclosed assembly instructions of the manufacturer for installation!

Remove the six hexagon socket screws on the back of the housing. Remove the rear lid.



Extract the rear flange. Be careful not to lose the O-ring.



Release the knurled screw and slide the upper rail away from the lower rail.

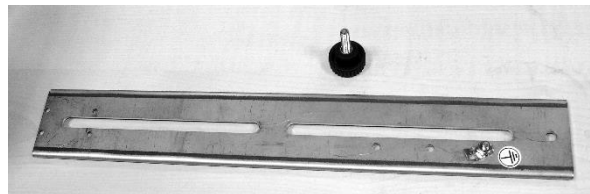

Secure the camera with tooth lock washer and pan head screw to the rail. Use the delivered hex wrench.

Note a distance between the camera front and the rail of approx. 10 mm (0.39 in)

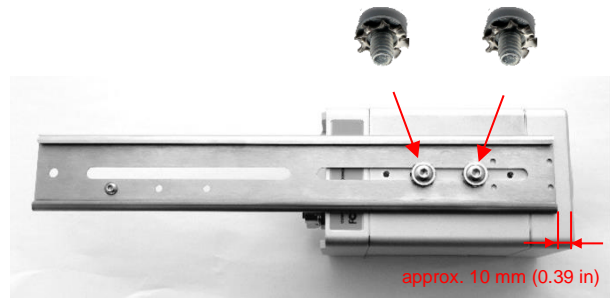

Fit the two cable glands to the rear lid.
wrench size W30 (30 mm/1.2 in)
torque about 10 Nm



Fix the earth tag with the nut on one of the cable glands (on the inner side of the rear lid).



Mount the sealing inner and the end cap to each cable.

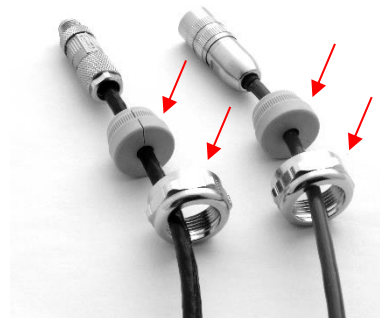

Fix the earth cable onto the rail.

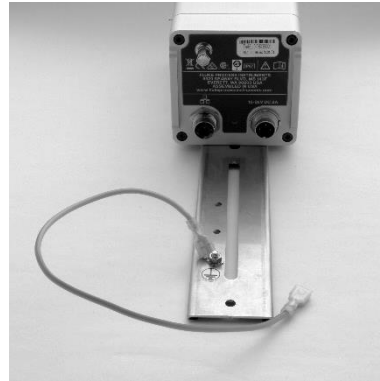

Pass all cables through the enclosure cable glands. Do not tight the end caps for the moment. Plug the connectors to the camera.

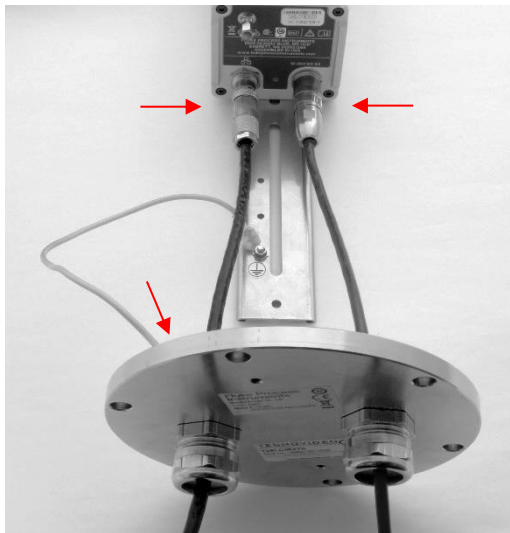

Connect the protective inductor on the inner side of the rear lid.

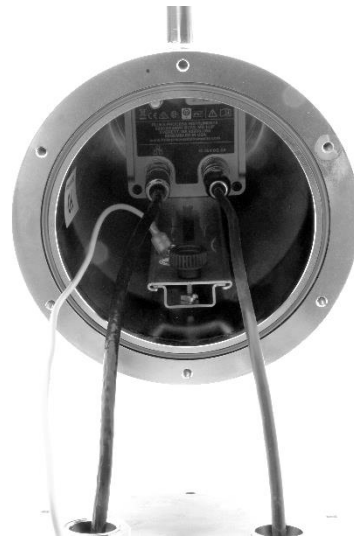

Slide the camera with the rail into the housing and secure it with the knurled screw.

Remount the rear lid onto the enclosure.

Fix two six hexagon socket screws each with a tooth lock washer as shown.



Fix the remaining four hexagon socket screws (without tooth lock washers) at the remaining positions.



Tight the end caps.
wrench size W30 (30 mm/1.2 in)
torque about 10 Nm)



7.3.5 Outdoor Enclosure (A-TV-ENC)

In case, the thermal imager must be mounted in outdoor environments, an outdoor enclosure (A-TV-ENC) ensures weatherproofed installations. It provides a high protection rate, a sunshield, and a temperature-controlled heater for cooler environments.

Figure 7-18: Outdoor Enclosure¹



7.3.5.1 Specification

Scope of delivery

- Enclosure with sunshield and Germanium window
- Double thermostat control heater
- Cable glands

Environment

Rating	IP66/IP67 EN60529 with cable glands
Ambient temperature	-30 to 50°C (-22 to 122°F)

Electrical

Double heater	115 / 230 VAC, 80 W
---------------	---------------------

Mechanical

Construction	Aluminum
Weight	4.1 kg (9 lb), without thermal camera
Cable entry	M16x1.5

¹ Photo © 2009, Videotec S.p.A.

Figure 7-19: Dimensions

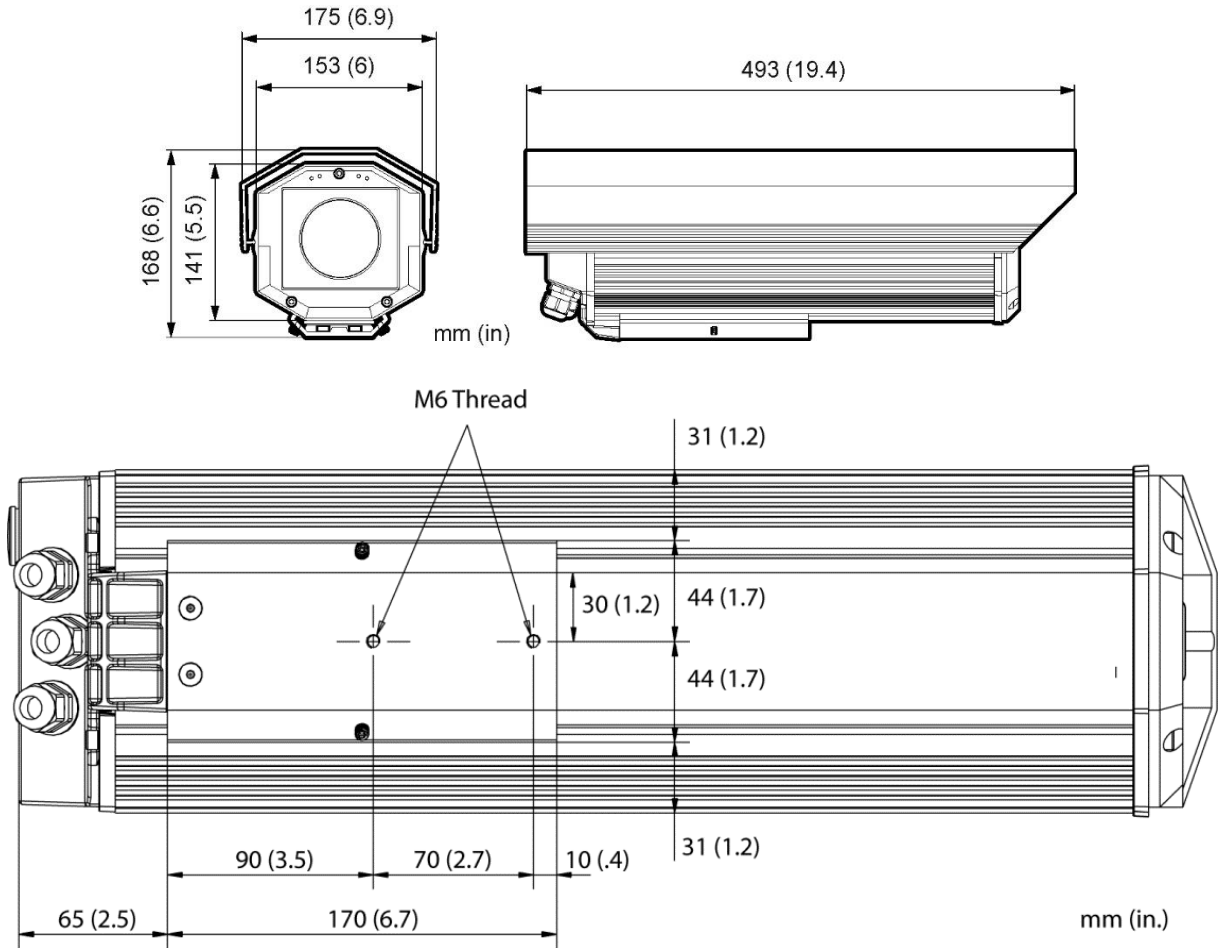

7.3.5.2 Installation

Note

The camera cannot be mounted in the outdoor enclosure with tele lens 4x or macro lens!

Note

To avoid erroneous readings, ensure that the transmission of 0.87 for the built-in protective window (Germanium) must be set in the thermal imager!

Note

For installation / commissioning of the internal heating element be referred to the enclosed instructions of the manufacturer.

When delivered, the housing cover is not yet in its final position.



Push the housing cover upwards until the key on the housing cover snaps into the slot of the housing body.

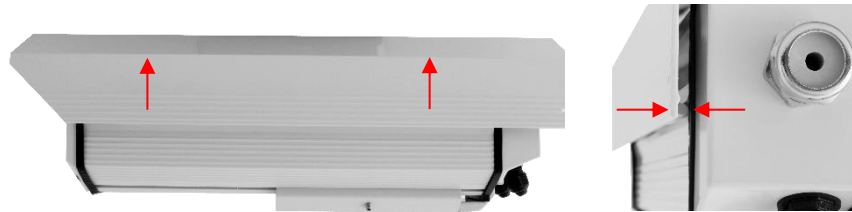

Remove the three hexagon socket screws on the back of the housing. Remove the rear lid with its inner sliding carriage.

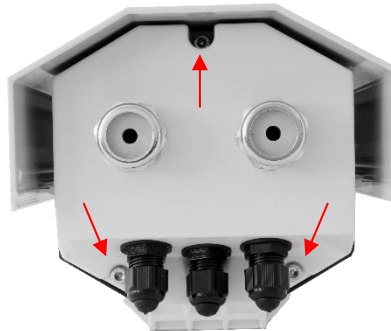

Secure the camera with tooth lock washer, inner ring and pan head screw to the rail. Use the delivered hex wrench.

Note a distance between the camera front and the rail of approx. 10 mm (0.39 in)

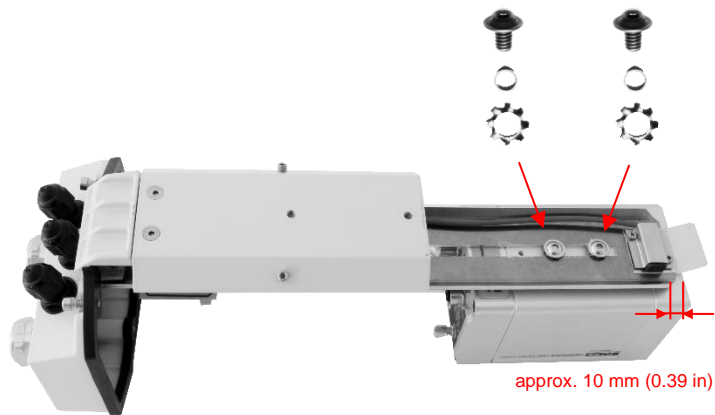

Mount the sealing inner and the end cap to each cable.

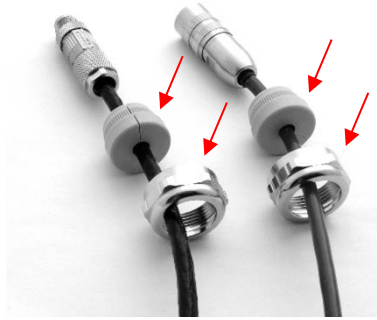

Pass all cables through the enclosure cable glands. Plug the connectors to the camera. Tight the end caps.

Installation with PoE requires only one cable. Close the unused cable gland with the enclosed sealing body.



Move the sliding carriage into the inner of the housing. Consider the rail system.

Connect the protective inductor on the labelled tag in the inner of the housing inner side.



Remount the rear lid onto the enclosure.

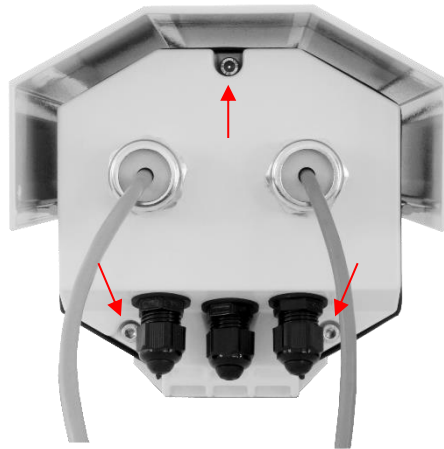

7.3.6 Swivel Bracket (A-BR-S)

The Swivel Bracket (A-BR-S) is to mount the camera in a moveable position, to correct in an easy way the pitch and yaw orientation. For a correct imager orientation, you can pitch (0° – 90°) and swivel (0° - 360°) the imager sighting axis. The base has a single control knob and a split-ball lock, to hold the specific head mount firmly in place.

Specification:

Circle diameter for three countersunk bolts	109.5 mm (4.3 in)
Countersunk bolts	6.3 mm (1/4") flat-head screws (not included)
Height with head mount beam	120 mm (4.7 in)
Weight with head mount beam	1.07 kg (2.4 lb)

Figure 7-20: Swivel Bracket



7.3.7 Junction Box (A-TV-JB)

The Junction Box (A-TV-JB) provides the space to the mount the power supplies, I/O modules, Ethernet converters and switches.

Figure 7-21: Junction Box

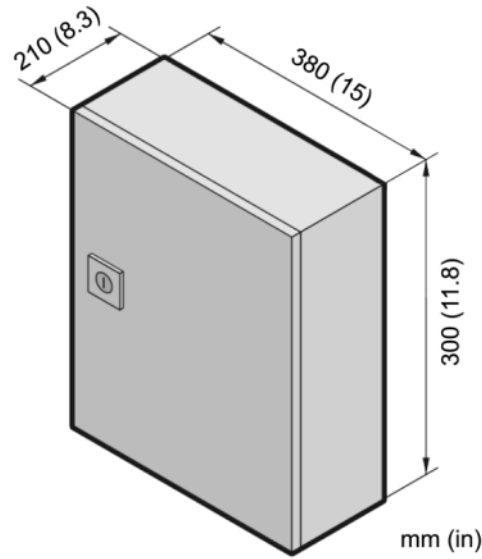

Specification:

Box	sheet steel, powder-coated
Dimensions (W x H x D)	380 x 300 x 210 mm (15 x 11.8 x 8.3 in)
Net weight	9.8 kg (22 lb)
Protection rate:	IP66 (NEMA 4)
Internal wiring	cable diameter max. 2.5 mm ² (AWG 14)
Box, fused	6 A

Delivery:

Connection box
 Cable entry system

7.3.8 Protective Windows (A-TV-PW)

The Protective Window (A-TV-PW) can be used to protect the camera's optics against dust and other contamination. The window is attached directly to the camera via the bayonet lock. The protective window is made from Germanium with a transmission factor of 0.94.

To avoid erroneous readings, ensure that the transmission for the protective window must be set in the camera via software.

Figure 7-22: Protective Window



8 Maintenance

Our sales representatives and customer service staff are always at your disposal for questions regarding applications, calibration, repair, and solutions to specific problems. Please contact your local sales representative if you need assistance. In many cases, problems can be solved over the telephone. If you need to return equipment for servicing, calibration or repair, please contact our Service Department before shipping. Phone numbers are listed at the beginning of this document.

8.1 Fail-Safe Operation

In cooperation with I/O modules and the ThermoView software, the camera provides a fail-safe system. That system is designed to alert the operator and provide a safe output in case of any system failure. Basically, it is designed to shut down the process in the event of a set-up error, system error, or a failure in the sensor electronics.



Warning

The Fail-Safe circuit should never be relied on exclusively to protect critical processes. Other safety devices should also be used to supplement this function!

8.2 Troubleshooting

Table 8-3: Troubleshooting

Symptom	Probable cause	Remedy
Power does not turn on.	Power switch is not on.	Turn on the Power Switch.
	AC adapter is not connected.	Connect AC adapter.
Measuring temperature is in error. (out of the specifications)	Wrong emissivity is set	Set correct emissivity.
	Ambient reflection calibration is not made	Execute ambient reflection calibration
	Focus is not met	Adjust focus correctly.
Noise problem	High voltage source is nearby.	Take a distance from the high voltage source.
	Connectors or cable touches to any noise source.	Turn off the power and take a distance from the noise source.

8.3 Cleaning the Lens

Keep the lens at all times. Care should be taken when cleaning the lens. To clean the window, do the following:

1. Lightly blow off loose particles with “canned” air (used for cleaning computer equipment) or a small squeeze bellows (used for cleaning camera lenses).
2. Gently brush off any remaining particles with a soft camel hair brush or a soft lens tissue (available from camera supply stores).
3. Clean remaining “dirt” using a cotton swab or soft lens tissue dampened in distilled water. Do not scratch the surface.

For fingerprints or other grease, use any of the following:

- Denatured alcohol
- Ethanol
- Kodak lens cleaner

Apply one of the above to the lens. Wipe gently with a soft, clean cloth until you see colors on the surface, then allow to air dry. Do not wipe the surface dry, as this may scratch the surface.

If silicones (used in hand creams) get on the window, gently wipe the surface with Hexane. Allow to air dry.

Note

Do not use any ammonia or any cleaners containing ammonia to clean the lens. This may result in permanent damage to the lens' surface!

9 Appendix



9.1 Field of View Calculator

It is important that the ThermoView camera is mounted at a distance from the target, sufficient to be able to “see” the entire area of interest. For this reason, the manufacturer provides a field of view calculating software called “Spot Size Calculator”, which allows the calculation of the thermal image size (Field of View FOV) and the pixel size (Instantaneous Field of View IFOV) for a given lens, based on a specific camera mounting distance.

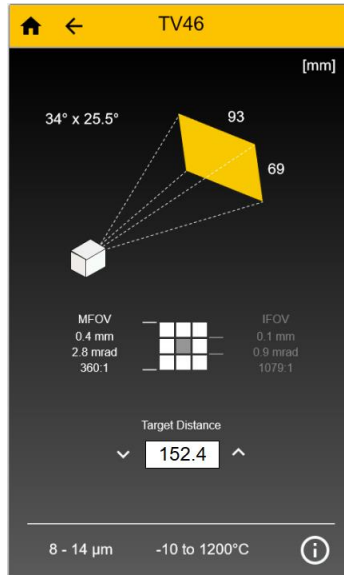
Figure 9-1: Field of View Calculator for the Camera



The “Spot Size Calculator” tool is available via the following stores and locations:

As app for Windows 10 based desktop computers, see Windows Store		
As app for Android mobiles, see Google Play Store		
As App for the iOS mobiles (iPhone and iPad), see App Store		
As html5 web page, see https://www.flukeprocessinstruments.com/SpotSizeCalculator/index.html		

9.2 Avoidance of Condensation

If environmental conditions make water cooling necessary, it is strictly recommended to check whether condensation will be a real problem or not. Water-cooling also causes a cooling of the air in the inner part of the sensor, thereby decreasing the capability of the air to hold water. The relative humidity increases and can reach 100% very quickly. In case of a further cooling, the surplus water vapor will condense out as water. The water will condense on the lenses and the electronics, resulting in possible damage to the sensor. Condensation can even happen on an IP65 sealed housing.

Note

There is no warranty repair possible in case of condensation within the housing!

To avoid condensation, the temperature of the cooling media and the flow rate must be selected to ensure a minimum device temperature. The minimum sensor temperature depends on the ambient temperature and the relative humidity. Please consider the following table.

Table 9-4: Minimum device temperatures [°C/°F]

		Relative Humidity [%]																				
		10	15	20	25	30	35	40	45	50	55	60	65	70	75	80	85	90	95	100		
Ambient Temperature [°C/°F]	0/ 32	0/ 32	0/ 32	0/ 32	0/ 32	0/ 32	0/ 32	0/ 32	0/ 32	0/ 32	0/ 32	0/ 32	0/ 32	0/ 32	0/ 32	0/ 32	0/ 32	0/ 32	0/ 32	0/ 32		
	5/ 41	0/ 32	0/ 32	0/ 32	0/ 32	0/ 32	0/ 32	0/ 32	0/ 32	0/ 32	0/ 32	0/ 32	0/ 32	0/ 32	0/ 32	0/ 32	0/ 32	0/ 32	0/ 32	5/ 41		
	10/ 50	0/ 32	0/ 32	0/ 32	0/ 32	0/ 32	0/ 32	0/ 32	0/ 32	0/ 32	0/ 32	0/ 32	0/ 32	0/ 32	5/ 41	5/ 41	5/ 41	5/ 41	5/ 41	5/ 41	10/ 50	
	15/ 59	0/ 32	0/ 32	0/ 32	0/ 32	0/ 32	0/ 32	0/ 32	0/ 32	0/ 32	5/ 41	5/ 41	5/ 41	5/ 41	10/ 50	10/ 50	10/ 50	10/ 50	10/ 50	10/ 50	15/ 59	
	20/ 68	0/ 32	0/ 32	0/ 32	0/ 32	0/ 32	5/ 41	5/ 41	5/ 41	10/ 50	10/ 50	10/ 50	10/ 50	15/ 59	15/ 59	15/ 59	15/ 59	15/ 59	15/ 59	15/ 59	20/ 68	
	25/ 77	0/ 32	0/ 32	0/ 32	0/ 32	5/ 41	5/ 41	10/ 50	10/ 50	10/ 50	10/ 50	15/ 59	15/ 59	15/ 59	20/ 68	20/ 68	20/ 68	20/ 68	20/ 68	20/ 68	25/ 77	
	30/ 86	0/ 32	0/ 32	0/ 32	5/ 41	5/ 41	10/ 50	10/ 50	15/ 59	15/ 59	15/ 59	20/ 68	20/ 68	20/ 68	20/ 68	25/ 77	25/ 77	25/ 77	25/ 77	25/ 77	30/ 86	
	35/ 95	0/ 32	0/ 32	5/ 41	10/ 50	10/ 50	15/ 59	15/ 59	20/ 68	20/ 68	20/ 68	25/ 77	25/ 77	25/ 77	25/ 77	30/ 86	30/ 86	30/ 86	30/ 86	30/ 86	35/ 95	
	40/ 104	0/ 32	5/ 41	10/ 50	10/ 50	15/ 59	20/ 68	20/ 68	20/ 68	25/ 77	25/ 77	25/ 77	30/ 86	30/ 86	30/ 86	35/ 95	35/ 95	35/ 95	35/ 95	35/ 95	40/ 104	
	45/ 113	0/ 32	10/ 50	15/ 59	15/ 59	20/ 68	25/ 77	25/ 77	25/ 77	30/ 86	30/ 86	35/ 95	35/ 95	35/ 95	35/ 95	40/ 104	40/ 104	40/ 104	40/ 104	40/ 104	45/ 113	
	50/ 122	5/ 41	10/ 50	15/ 59	20/ 68	25/ 77	25/ 77	30/ 86	30/ 86	35/ 95	35/ 95	35/ 95	40/ 104	40/ 104	40/ 104	45/ 113	45/ 113	45/ 113	45/ 113	45/ 113	50/ 122	
	60/ 140	15/ 59	20/ 68	25/ 77	30/ 86	30/ 86	35/ 95	40/ 104	40/ 104	40/ 104	45/ 113	45/ 113	50/ 122	50/ 122	50/ 122	50/ 122	50/ 122	50/ 122	50/ 122	50/ 122	60/ 140	
	70/ 158	20/ 68	25/ 77	35/ 95	35/ 95	40/ 104	45/ 113	45/ 113	50/ 122	50/ 122	50/ 122	50/ 122	50/ 122	60/ 140	60/ 140	60/ 140	60/ 140	60/ 140	60/ 140	60/ 140		
	80/ 176	25/ 77	35/ 95	40/ 104	45/ 113	50/ 122	50/ 122	60/ 140	60/ 140	60/ 140	60/ 140	60/ 140	60/ 140									
	90/ 194	35/ 95	40/ 104	50/ 122	50/ 122	50/ 122	60/ 140	60/ 140	60/ 140													
	100/ 212	40/ 104	50/ 122	50/ 122	60/ 140	60/ 140																

Example:

Ambient temperature = 50°C, Relative humidity = 40 % → Minimum device temperature = 30°C

The use of lower temperatures is at your own risk!

9.3 Determination of Emissivity

Emissivity is a measure of an object's ability to absorb and emit infrared energy. It can have a value between 0 and 1.0. For example, a mirror has an emissivity of < 0.1 , while the so-called *blackbody* reaches an emissivity value of 1.0. If a higher than actual emissivity value is set, the output will read low, provided the target temperature is above its ambient temperature. For example, if you have set 0.95 and the actual emissivity is 0.9, the temperature reading will be lower than the true temperature.

An object's emissivity can be determined by one of the following methods:

- Determine the actual temperature of the material using an RTD (PT100), a thermocouple, or any other suitable contact temperature method. Next, measure the object's temperature and adjust emissivity setting until the correct temperature value is reached. This is the correct emissivity for the measured material.
- For relatively low temperatures (up to 260°C / 500°F) place a plastic sticker on the object to be measured. This sticker should be large enough to cover the target spot. Next, measure the sticker's temperature using an emissivity setting of 0.95. Finally, measure the temperature of an adjacent area on the object and adjust the emissivity setting until the same temperature is reached. This is the correct emissivity for the measured material.
- If possible, apply flat black paint to a portion of the surface of the object. The emissivity of the paint is 0.95. Next, measure the temperature of the painted area using an emissivity setting of 0.95. Finally, measure the temperature of an adjacent area on the object and adjust the emissivity until the same temperature is reached. This is the correct emissivity for the measured material.

9.4 Typical Emissivity Values

The following table provides a brief reference guide for determining emissivity and can be used when one of the above methods is not practical. Emissivity values shown in the table are only approximate, since several parameters may affect the emissivity of a material. These include the following:

- Temperature
- Angle of measurement
- Geometry (plane, concave, convex)
- Thickness
- Surface quality (polished, rough, oxidized, sandblasted)
- Spectral range of measurement
- Transmission (e.g. thin films plastics)

To optimize surface temperature measurements, consider the following guidelines:

- Determine the object's emissivity using the instrument, which is also to be used for temperature measurements.
- Avoid reflections by shielding the object from surrounding temperature sources.
- For higher temperature objects, use instruments with the shortest wavelength possible.
- For translucent materials such as plastic foils or glass, ensure that the background is uniform and lower in temperature than the object.
- Mount the instrument perpendicular to the surface, if possible. In all cases, do not exceed angles more than 30° from incidence.

Table 9-1: Typical Emissivity Values for Metals

Material	8 – 14 μm
Aluminum	
Unoxidized	0.02-0.1
Oxidized	0.2-0.4
Alloy A3003, Oxidized	0.3
Roughened	0.1-0.3
Polished	0.02-0.1
Brass	
Polished	0.01-0.05
Burnished	0.3
Oxidized	0.5
Chromium	0.02-0.2
Oxidized	
Copper	
Polished	0.03
Roughened	0.05-0.1
Oxidized	0.4-0.8
Gold	0.01-0.1
Haynes	
Alloy	0.3-0.8
Inconel	
Oxidized	0.7-0.95
Sandblasted	0.3-0.6
polished	0.15
Iron	
Oxidized	0.5-0.9
Unoxidized	0.05-0.2
Rusted	0.5-0.7
Molten	
Iron, Cast	
Oxidized	0.6-0.95
Unoxidized	0.2
Molten	0.2-0.3
Iron, Wrought	
Dull	0.9
Lead	
Polished	0.05-0.1
Rough	0.4
Oxidized	0.2-0.6
Magnesium	0.02-0.1
Mercury	0.05-0.15
Molybdenum	
Oxidized	0.2-0.6
Unoxidized	0.1

Material	8 – 14 μm
Monel (Ni-Cu)	0.1-0.14
Oxidized	0.7-0.9
Nickel	
Oxidized	0.2-0.5
Electrolytic	0.05-0.15
Platinum	
Black	0.9
Silver	0.02
Steel	
Cold-Rolled	0.7-0.9
Ground Sheet	0.4-0.6
Polished Sheet	0.1
Molten	
Oxidized	0.7-0.9
Stainless	0.1-0.8
Tin (Unoxidized)	0.05
Titanium	
Polished	0.05-0.2
Oxidized	0.5-0.6
Tungsten	0.03
Polished	0.03-0.1
Zinc	
Oxidized	0.1
Polished	0.02

Table 9-2: Typical Emissivity Values for Non-Metals

Material	8 – 14 μm
Asbestos	0.95
Asphalt	0.95
Basalt	0.7
Carbon	
Unoxidized	0.8-0.9
Graphite	0.7-0.8
Carborundum	0.9
Ceramic	0.95
Clay	0.95
Coke	0.95-1.00
Concrete	0.95
Cloth	0.95
Glass	
Plate	0.85
“Gob”	
Gravel	0.95
Gypsum	0.8-0.95
Ice	0.98
Limestone	0.98
Paint (non-al.)	0.9-0.95
Paper (any color)	0.95
Plastic, opaque at 500 μm thickness (20 mils)	0.95
Rubber	0.95
Sand	0.9
Snow	0.9
Soil	0.9-0.98
Water	0.93
Wood, Natural	0.9-0.95